

# American Industrial Heat Transfer Inc.

Manufacturer of Quality Heat Exchangers



www.aihti.com

## AA - STA SERIES



### Fixed Tube Bundle Liquid Cooled

## HEAT EXCHANGERS

- Computer generated data sheet available for any application
- Operating pressure for tubes 150 PSI.
- Operating pressure for shell 300 PSI.
- Operating temperature 300 °F.
- Can be customized to fit any applications.
- Cools: Fluid power systems, rock crushers, presses, shears, lubrication equipment for paper machinery, gear drives, marine transmissions, etc.

note: AIHTI reserves the right to make reasonable design changes without notice.

# AA & STA Series overview

## AA SERIES

Fixed tube construction heat exchangers with NPT connections. Made of brass with copper cooling tubes and cast iron end bonnets. Standard sizes from 2" through 8" diameters, and from 1.3 to 200 sq.ft. Standard one, two, and four pass models are available. Options include 90/10 copper nickel and 316 stainless steel cooling tubes, bronze end bonnets and zinc anodes. Can be customized to fit your requirements.

Optional 10" diameter units in brass are available upon request.



## STA SERIES

Similar in design to AA series with fixed tube construction and NPT connections made of all 316 stainless steel. Standard sizes from 2" through 8" diameters. From 1.3 to 200 sq. ft. Standard one, two and four pass models are available. Larger diameters available upon request. Can be customized to fit your requirements.



**AC-ACF-ACHM Series**

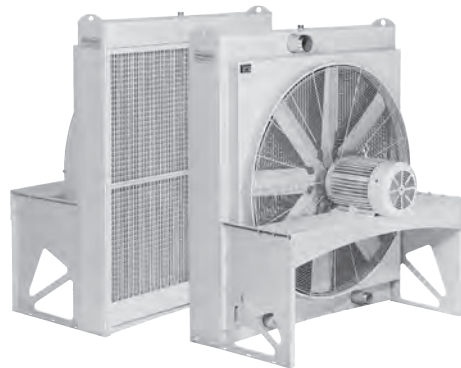

**AOCs Series**



**ACL Series**



**EOC - EOCF Series**

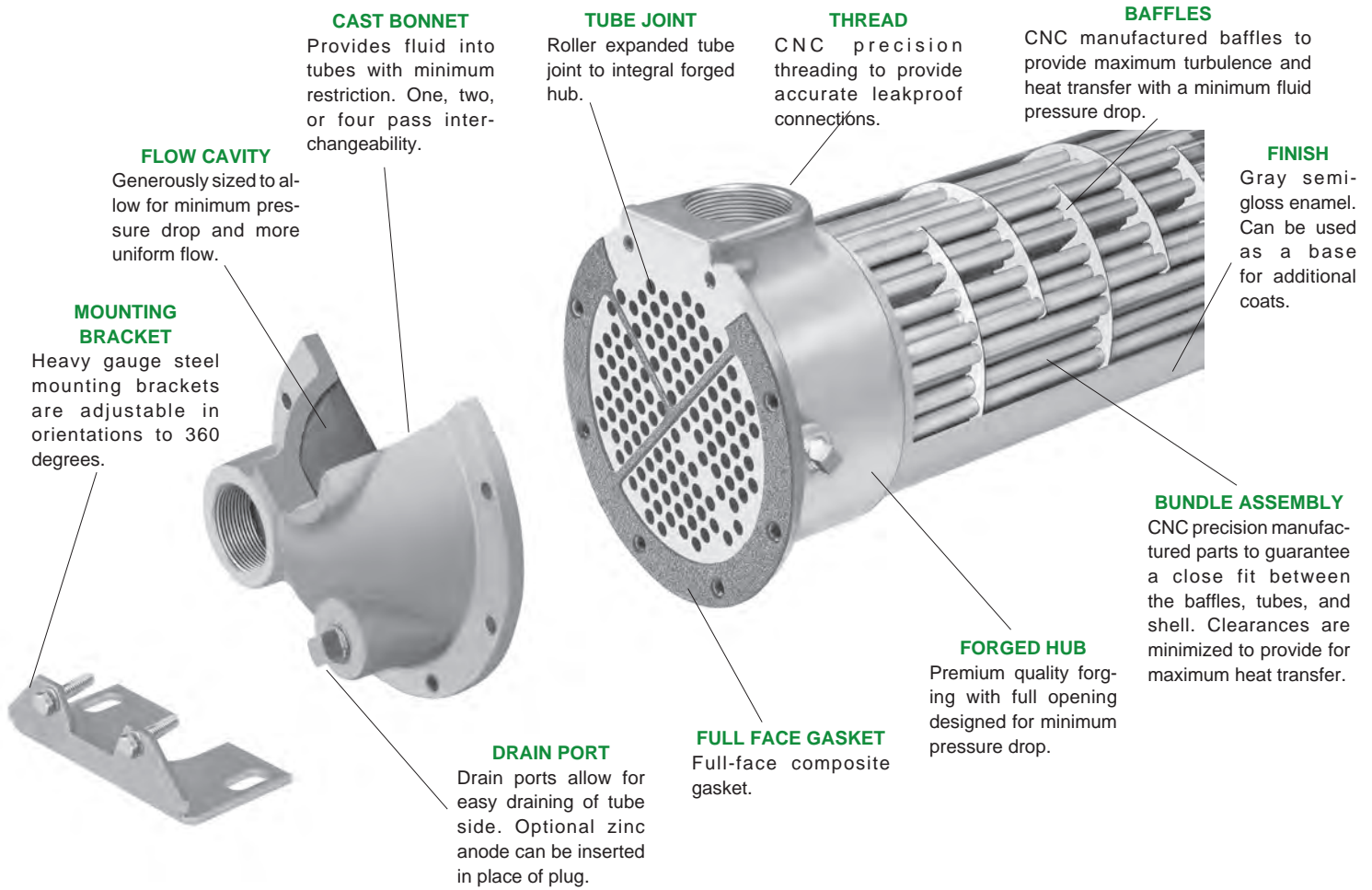

## Example Model

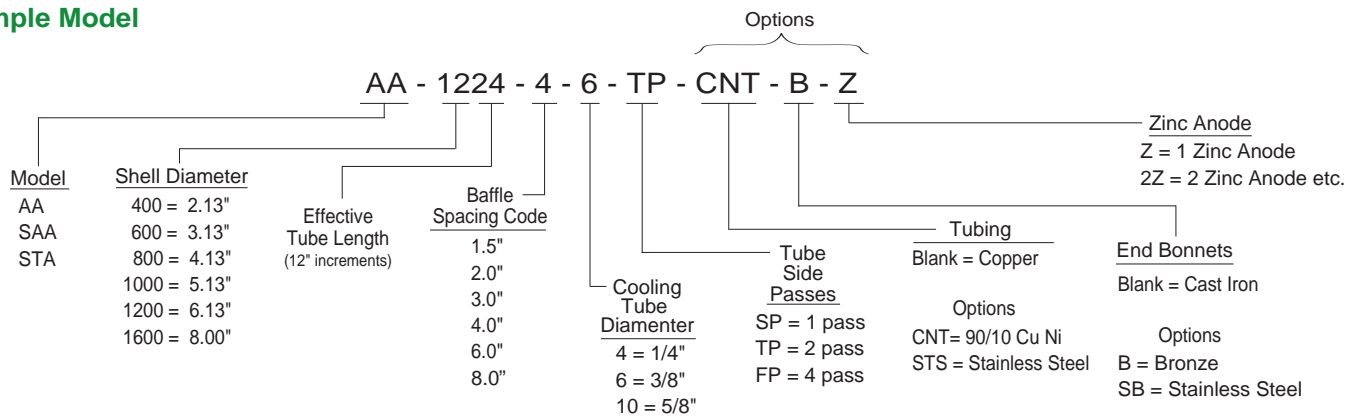

## STANDARD CONSTRUCTION MATERIALS & RATINGS

Standard Model	AA Series	SAA Series*	STA Series	Standard Unit Ratings
Shell	Brass	Steel	316 Stainless Steel	Operating Pressure Tubes 150 psig
Tubes	Copper	Copper	316 Stainless Steel	
Baffle	Aluminum / Brass	Aluminum / Brass	316 Stainless Steel	
Integral End Hub	Forged Brass	Forged Brass	316 Stainless Steel	Operating Pressure Shell 300 psig
End Bonnets	Cast Iron	Cast Iron	316 Stainless Steel	Operating Temperature 300 °F
Mounting Brackets	Steel	Steel	Steel	
Gasket	Hypalon Composite	Hypalon Composite	Hypalon Composite	

\*Offered in 5" through 8" shell diameter.

note: AIHTI reserves the right to make reasonable design changes without notice.

# AA & STA Series selection

## STEP 1: Calculate the heat load

The heat load in BTU/HR or (Q) can be derived by using several methods. To simplify things, we will consider general specifications for hydraulic system oils and other fluids that are commonly used with shell & tube heat exchangers.

Terms			
GPM	= Gallons Per Minute	Kw	= Kilowatt (watts x 1000)
CN	= Constant Number for a given fluid	T <sub>in</sub>	= Hot fluid entering temperature in °F
ΔT	= Temperature differential across the potential	T <sub>out</sub>	= Hot fluid exiting temperature in °F
PSI	= Pounds per Square Inch (pressure) of the operating side of the system	t <sub>in</sub>	= Cold fluid temperature entering in °F
MHP	= Horsepower of the electric motor driving the hydraulic pump	t <sub>out</sub>	= Cold fluid temperature exiting in °F
		Q	= BTU / HR

For example purposes, a hydraulic system has a 125 HP (93Kw) electric motor installed coupled to a pump that produces a flow of 80 GPM @ 2500 PSIG. The temperature differential of the oil entering the pump vs exiting the system is about 5.3°F. Even though our return line pressure operates below 100 psi, we must calculate the system heat load potential (Q) based upon the prime movers (pump) capability. We can use one of the following equations to accomplish this:

To derive the required heat load (Q) to be removed by the heat exchanger, apply ONE of the following. Note: The calculated heat loads may differ slightly from one formula to the next. This is due to assumptions made when estimating heat removal requirements. The factor (ν) represents the percentage of the overall input energy to be rejected by the heat exchanger. The (ν) factor is generally about 30% for most hydraulic systems, however it can range from 20%-70% depending upon the installed system components and heat being generated (ie. servo valves, proportional valves, etc...will increase the percentage required).

FORMULA	EXAMPLE
A) Q = GPM x CN x actual ΔT	A) Q = 80 x 210 x 5.3°F = 89,040 BTU/HR
B) Q = [ (PSI x GPM) / 1714 ] x (ν) x 2545	B) Q = [(2500x80)/1714] x .30 x 2545 = 89,090 BTU/HR
C) Q = MHP x (ν) x 2545	C) Q = 125 x .30 x 2545 = 95,347 BTU/HR
D) Q = Kw to be removed x 3415	D) Q = 28 x 3415 = 95,620 BTU/HR
E) Q = HP to be removed x 2545	E) Q = 37.5 x 2545 = 95,437 BTU/HR

### Constant for a given fluid ( CN )

- 1) Oil ..... CN = 210
- 2) Water..... CN = 500
- 3) 50% E. Glycol..... CN = 450

## STEP 2: Calculate the Mean Temperature Difference

When calculating the MTD you will be required to choose a liquid flow rate to derive the **Cold Side** ΔT. If your water flow is unknown you may need to assume a number based on what is available. As a normal rule of thumb, for oil to water cooling a 2:1 oil to water ratio is used. For applications of water to water or 50 % Ethylene Glycol to water, a 1:1 ratio is common.

FORMULA	EXAMPLE
<b>HOT FLUID</b> ΔT = $\frac{Q}{CN \times GPM}$ Oil	ΔT = $\frac{89,090 \text{ BTU/hr}}{210 \text{ CN} \times 80 \text{ GPM}}$ (from step 1, item B) = 5.3°F = ΔT Rejected
<b>COLD FLUID</b> Δt = $\frac{BTU / hr}{CN \times GPM}$ Water	Δt = $\frac{89,090 \text{ BTU/hr}}{500 \text{ CN} \times 40 \text{ GPM}}$ (for a 2:1 ratio) = 4.45°F = ΔT Absorbed
T <sub>in</sub> = Hot Fluid entering temperature in degrees F	T <sub>in</sub> = 125.3 °F
T <sub>out</sub> = Hot Fluid exiting temperature in degrees F	T <sub>out</sub> = 120.0 °F
t <sub>in</sub> = Cold Fluid entering temperature in degrees F	t <sub>in</sub> = 70.0 °F
t <sub>out</sub> = Cold Fluid exiting temperature in degrees F	t <sub>out</sub> = 74.5 °F
$\frac{T_{out} - t_{in}}{T_{in} - t_{out}} = \frac{S[\text{smaller temperature difference}]}{L[\text{larger temperature difference}]} = \left( \frac{S}{L} \right)$	$\frac{120.0^\circ\text{F} - 70.0^\circ\text{F} = 50.0^\circ\text{F}}{125.3^\circ\text{F} - 74.5^\circ\text{F} = 50.8^\circ\text{F}} = \frac{50.0^\circ\text{F}}{50.8^\circ\text{F}} = .984$

## STEP 3: Calculate Log Mean Temperature Difference (LMTD)

To calculate the LMTD please use the following method;

L = Larger temperature difference from step 2.  
M = S/L number (LOCATED IN TABLE A).

$$LMTD_i = L \times M$$

To correct the LMTD<sub>i</sub> for a multipass heat exchangers calculate **R** & **K** as follows:

$$LMTD_i = 50.8 \times .992 \text{ (FROM TABLE A)} = 50.39$$

FORMULA	EXAMPLE
$R = \frac{T_{in} - T_{out}}{t_{out} - t_{in}}$	$R = \frac{125.3^\circ\text{F} - 120.0^\circ\text{F}}{74.5^\circ\text{F} - 70.0^\circ\text{F}} = \frac{5.3^\circ\text{F}}{4.5^\circ\text{F}} = \{1.17=R\}$
$K = \frac{t_{out} - t_{in}}{T_{in} - t_{in}}$	$K = \frac{74.5^\circ\text{F} - 70.0^\circ\text{F}}{124.5^\circ\text{F} - 70.0^\circ\text{F}} = \frac{4.5^\circ\text{F}}{55.4^\circ\text{F}} = \{0.081=K\}$

Locate the correction factor CF<sub>B</sub>  
(FROM TABLE B)  
LMTD<sub>c</sub> = LMTD<sub>i</sub> x CF<sub>B</sub>  
LMTD<sub>c</sub> = 50.39 x 1 = **50.39**

## STEP 4: Calculate the area required

Required Area sq.ft. =  $\frac{Q \text{ (BTU / HR)}}{LMTD_c \times U \text{ (FROM TABLE C)}}$  =  $\frac{89,090}{50.39 \times 100}$  = **17.68 sq.ft.**

## STEP 5: Selection

a) From TABLE E choose the correct series size, baffle spacing, and number of passes that best fits your flow rates for both shell and tube side. Note that the tables suggest minimum and maximum information. Try to stay within the 20-80 percent range of the indicated numbers.

Example

Oil Flow Rate = 80 GPM = Series Required from Table E = **1200 Series**  
 Baffle Spacing from Table E = **4**  
 Water Flow Rate = 40 GPM = Passes required in 1200 series = **4 (FP)**

b) From TABLE D choose the heat exchanger model size based upon the sq.ft. or surface area in the series size that will accommodate your flow rate.

Example

Required Area = 17.68sq.ft. Closest model required based upon sq.ft. & series = **AA-1224-4-6-FP**

If you require a computer generated data sheet for the application, or if the information that you are trying to apply does not match the corresponding information, please contact our engineering services department for further assistance.

**TABLE A- FACTOR M/LMTD = L x M**

S/L	M	S/L	M	S/L	M	S/L	M
.01	.215	.25	.541	.50	.721	.75	.870
.02	.251	.26	.549	.51	.728	.76	.874
.03	.277	.27	.558	.52	.734	.77	.879
.04	.298	.28	.566	.53	.740	.78	.886
		.29	.574	.54	.746	.79	.890
.05	.317	.30	.582	.55	.753	.80	.896
.06	.334	.31	.589	.56	.759	.81	.902
.07	.350	.32	.597	.57	.765	.82	.907
.08	.364	.33	.604	.58	.771	.83	.913
.09	.378	.34	.612	.59	.777	.84	.918
.10	.391	.35	.619	.60	.783	.85	.923
.11	.403	.36	.626	.61	.789	.86	.928
.12	.415	.37	.634	.62	.795	.87	.934
.13	.427	.38	.641	.63	.801	.88	.939
.14	.438	.39	.648	.64	.806	.89	.944
.15	.448	.40	.655	.65	.813	.90	.949
.16	.458	.41	.662	.66	.818	.91	.955
.17	.469	.42	.669	.67	.823	.92	.959
.18	.478	.43	.675	.68	.829	.93	.964
.19	.488	.44	.682	.69	.836	.94	.970
.20	.497	.45	.689	.70	.840	.95	.975
.21	.506	.46	.695	.71	.848	.96	.979
.22	.515	.47	.702	.72	.852	.97	.986
.23	.524	.48	.709	.73	.858	.98	.991
.24	.533	.49	.715	.74	.864	.99	.995

**TABLE D- Surface Area**

Model Number	Surface Area in Sq.ft.			Model Number	Surface Area in Sq.ft.		
	1/4" O.D Tubing	3/8" O.D Tubing	5/8 O.D Tubing		1/4" O.D Tubing	3/8" O.D Tubing	5/8 O.D Tubing
AA-408	1.35	-	-	AA-1224	33.76	23.55	11.78
				AA-1236	50.63	35.33	17.66
AA-608	2.62	-	-	AA-1248	67.51	47.10	23.55
AA-614	4.58	-	-	AA-1260	87.39	58.88	29.44
AA-624	7.85	-	-	AA-1272	101.27	70.65	35.33
AA-636	11.78	-	-	AA-1284	118.14	82.43	41.21
				AA-1296	135.02	94.20	47.10
AA-814	8.55	-	-				
AA-824	14.65	-	-	AA-1624	58.61	41.21	23.55
AA-836	21.2	-	-	AA-1636	87.92	61.82	35.33
AA-848	28.3	-	-	AA-1648	117.23	82.43	47.10
				AA-1660	146.53	103.03	58.88
AA-1014	13.74	9.16	4.58	AA-1672	175.84	123.64	70.65
AA-1024	23.55	15.70	7.85	AA-1684	205.15	144.24	82.43
AA-1036	35.33	23.55	11.78	AA-1696	234.45	164.85	94.20
AA-1048	47.10	31.40	15.70	AA-16108	263.76	185.46	105.98
AA-1060	58.88	39.25	19.63	AA-16120	293.07	206.06	117.75

**TABLE B- LMTD correction factor for Multipass Exchangers**

R	K														
	.05	.1	.15	.2	.25	.3	.35	.4	.45	.5	.6	.7	.8	.9	1.0
.2	1	1	1	1	1	1	1	.999	.993	.984	.972	.942	.908	.845	.71
.4	1	1	1	1	1	1	.994	.983	.971	.959	.922	.855	.70		
.6	1	1	1	1	1	.992	.980	.965	.948	.923	.840				
.8	1	1	1	1	.995	.981	.965	.945	.916	.872					
1.0	1	1	1	1	.988	.970	.949	.918	.867	.770					
2.0	1	1	.977	.973	.940	.845	.740								
3.0	1	1	.997	.933	.835										
4.0	1	.993	.950	.850											
5.0	1	.982	.917												
6.0	1	.968	.885												
8.0	1	.930													
10.0	.996	.880													
12.0	.985	.720													
14.0	.972														
16.0	.958														
18.0	.940														
20.0	.915														

**TABLE E- Flow Rate for Shell & Tube**

Shell dia . Code	Max. liquid Flow - Shell Side					Liquid Flow - Tube Side								
	Baffle Spacing					SP			TP			FP		
	1.5	2	3	4	6	Min.	Max.	Min.	Max.	Min.	Max.	Min.	Max.	
400	10	19	-	-	-	3.5	20	-	-	-	-	-	-	
600	15	20	25	30	-	7.5	48	3.5	24	2	12			
800	20	35	45	60	-	10	70	4.5	38	3	21			
1000	24	35	60	70	-	20	120	10	70	5.0	37			
1200	35	45	70	100	120	30	220	15	112	7.5	56			
1600	38	70	150	200	220	57	300	29	180	14	90			

**TABLE C**

U	TUBE FLUID	SHELL FLUID
400	Water	Water
350	Water	50% E. Glycol
100	Water	Oil
300	50% E. Glycol	50% E. Glycol
90	50% E. Glycol	Oil

# AA & STA Series performance

## Instructions

The selection chart provided contains an array of popular sizes for quick sizing. It does not provide curves for all models available. Refer to page 24 & 25 for detailed calculation information.

Computer selection data sheets for standard or special models are available through the engineering department of American Industrial. To use the followings graphs correctly, refer to the instruction notes "1-5".

- 1) HP Curves are based upon a 40°F approach temperature; for example: oil leaving a cooler at 125°F, using 85°F cooling water (125°F - 85°F = 40°F).
- 2) The oil to water ratio of 1:1 or 2:1 means that for every 1 gallon of oil circulated, a minimum of 1 or 1/2 gallon (respectively) of 85°F water

must be circulated to match the curve results.

- 3) OIL PRESSURE DROP CODING: ♣ = 5 psi; ☆ = 10 psi; ○ = 20 psi; △ = 50psi. Curves that have no pressure drop code symbols indicate that the oil pressure drop is less than 5 psi for the flow rate shown.
- 4) Pressure Drop is based upon oil with an average viscosity of 100 SSU. If the average oil viscosity is other than 100 SSU, then multiply the indicated Pressure Drop by the corresponding value from corrections table A.
- 5) Corrections for approach temperature and oil viscosity are as follows:

$$H.P. (In Cooler) = H.P. (Actual Heat Load) \times \left( \frac{40}{Actual Approach} \right) \times B.$$

## HEAT ENERGY DISSIPATION RATES (Basic Stock Model)

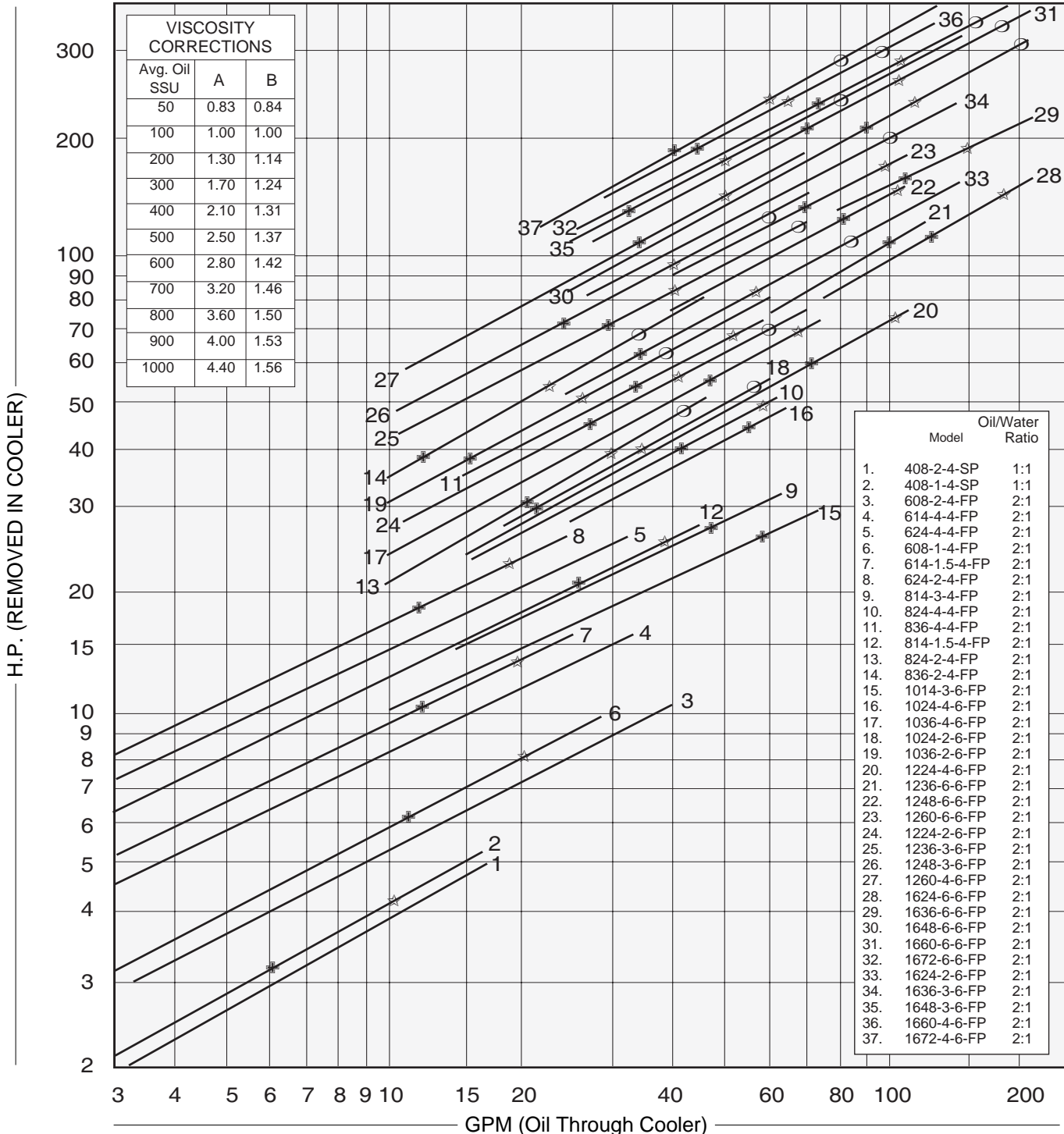

# AA & STA Series *dimensions*

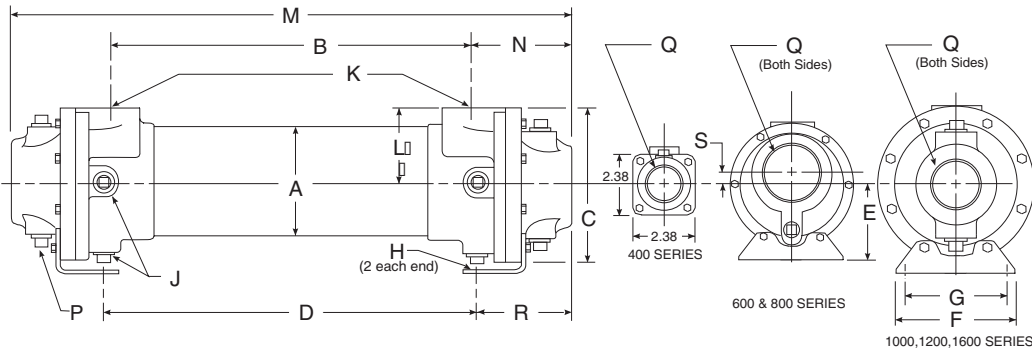

**Single Pass (SP)**

Model	M	N	P NPT	Q NPT	R	S
AA-408	11.00	2.38	-	1.00	-	-
AA-608	11.25	-	-	-	-	-
AA-614	17.25	2.56	(2)	1.50	3.06	0.38
AA-624	27.25	.38				
AA-814	18.00	-	-	-	-	-
AA-824	28.50	3.44	(2)	2.00	2.56	0.50
AA-836	40.00	.38				
AA-1014	18.50	-	-	-	-	-
AA-1024	28.50	3.69	(4)	2.50	3.38	-
AA-1036	40.50	.38				
AA-1224	29.25	-	-	-	-	-
AA-1236	41.25	-	-	-	-	-
AA-1248	53.25	4.25	(4)	3.00	3.75	-
AA-1260	65.25	.38				
AA-1272	77.25	-	-	-	-	-
AA-1624	31.25	-	-	-	-	-
AA-1636	43.25	-	-	-	-	-
AA-1648	55.25	6.52	(4)	4.00	5.25	-
AA-1660	67.25	.50				
AA-1672	79.25	-	-	-	-	-
AA-1684	91.25	-	-	-	-	-

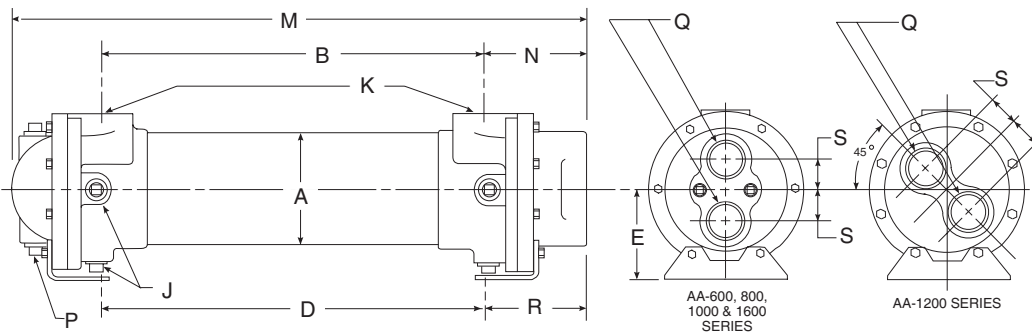

**Two Pass (TP)**

Model	M	N	P NPT	Q NPT	R	S
AA-608	10.75	-	-	-	-	-
AA-614	16.75	2.44	(2)	1.00	2.94	1.00
AA-624	26.75	.38				
AA-814	17.62	-	-	-	-	-
AA-824	27.62	3.44	(2)	1.25	2.56	1.19
AA-836	39.62	.38				
AA-1014	18.50	-	-	-	-	-
AA-1024	28.50	3.69	(2)	1.50	3.50	1.50
AA-1036	40.50	.38				
AA-1224	28.75	-	-	-	-	-
AA-1236	40.75	-	-	-	-	-
AA-1248	52.75	4.25	(2)	2.00	3.75	1.56
AA-1260	64.75	.38				
AA-1272	76.75	-	-	-	-	-
AA-1624	30.50	-	-	-	-	-
AA-1636	42.50	-	-	-	-	-
AA-1648	54.50	6.00	(2)	2.50	5.25	2.25
AA-1660	66.50	.50				
AA-1672	78.50	-	-	-	-	-
AA-1684	90.50	-	-	-	-	-

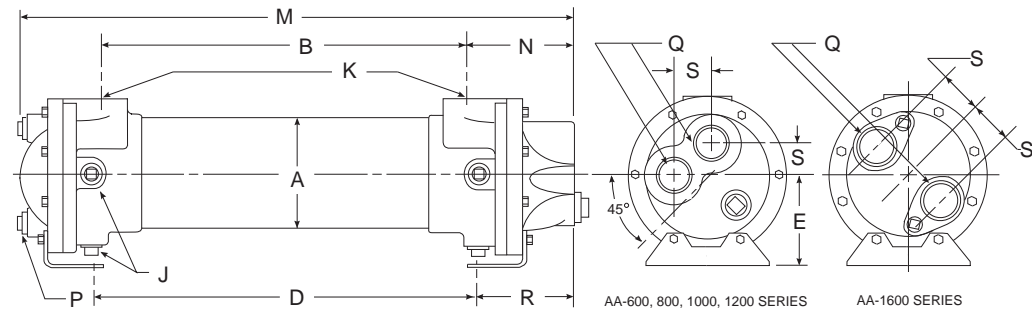

**Four Pass (FP)**

Model	M	N	P NPT	Q NPT	R	S
AA-608	10.88	-	-	-	-	-
AA-614	16.88	2.44	(2)	.75	2.81	1.00
AA-624	26.88	.38				
AA-814	17.62	-	-	-	-	-
AA-824	27.62	3.44	(2)	.75	2.56	1.06
AA-836	39.62	.38				
AA-1014	18.50	-	-	-	-	-
AA-1024	28.50	3.80	(3)	1.00	3.25	1.69
AA-1036	40.50	.38				
AA-1224	29.50	-	-	-	-	-
AA-1236	41.50	-	-	-	-	-
AA-1248	53.50	4.56	(3)	1.50	3.75	2.00
AA-1260	65.50	.50				
AA-1272	77.50	-	-	-	-	-
AA-1624	30.75	-	-	-	-	-
AA-1636	42.75	-	-	-	-	-
AA-1648	54.75	6.08	(4)	2.00	5.25	2.62
AA-1660	66.75	.50				
AA-1672	78.75	-	-	-	-	-
AA-1684	90.75	-	-	-	-	-

## COMMON DIMENSIONS & WEIGHTS

Model	A	B	C	D	E	F	G	H	J NPT	K NPT	L	Approx. Weight	Model
AA-408	2.125	6.25	-	-	-	-	-	-	-	.50	1.69	7	AA-408
AA-608	-	6.12	-	5.12	-	-	-	-	-	-	-	12	AA-608
AA-614	3.125	12.12	4.19	11.12	2.44	3.50	2.50	.38øx.88	(2) .25	1.00	2.44	16	AA-614
AA-624	-	22.12	-	21.12	-	-	-	-	-	-	-	20	AA-624
AA-814	-	11.12	-	12.88	-	-	-	-	-	-	-	37	AA-814
AA-824	4.125	21.12	5.88	22.88	3.50	4.75	3.50	.50øx1.62	(6) .38	1.50	3.12	47	AA-824
AA-836	-	33.12	-	34.88	-	-	-	-	-	-	-	67	AA-836
AA-1014	-	11.12	-	11.75	-	-	-	-	-	-	-	45	AA-1014
AA-1024	5.125	21.12	6.50	21.75	3.75	5.00	4.00	.50øx.88	(6) .38	1.50	3.62	60	AA-1024
AA-1036	-	33.12	-	33.75	-	-	-	-	-	-	-	82	AA-1036
AA-1224	-	20.50	-	21.50	-	-	-	-	-	-	-	90	AA-1224
AA-1236	-	32.50	-	33.50	-	-	-	-	-	-	-	110	AA-1236
AA-1248	6.125	44.50	7.50	45.50	4.12	6.00	5.00	.50øx.88	(6) .38	2.00	4.25	130	AA-1248
AA-1260	-	56.50	-	57.50	-	-	-	-	-	-	-	150	AA-1260
AA-1272	-	68.50	-	69.50	-	-	-	-	-	-	-	180	AA-1272
AA-1624	-	19.00	-	20.50	-	-	-	-	-	-	-	160	AA-1624
AA-1636	-	31.00	-	32.50	-	-	-	-	-	-	-	185	AA-1636
AA-1648	-	43.00	-	44.50	-	-	-	-	-	-	-	205	AA-1648
AA-1660	8.00	55.00	9.75	56.50	5.38	8.25	7.00	.62øx1.12	(6) .38	3.00	5.62	235	AA-1660
AA-1672	-	67.00	-	68.50	-	-	-	-	-	-	-	280	AA-1672
AA-1684	-	79.00	-	80.50	-	-	-	-	-	-	-	320	AA-1684

note: AIHTI reserves the right to make reasonable design changes without notice.

# STA Series

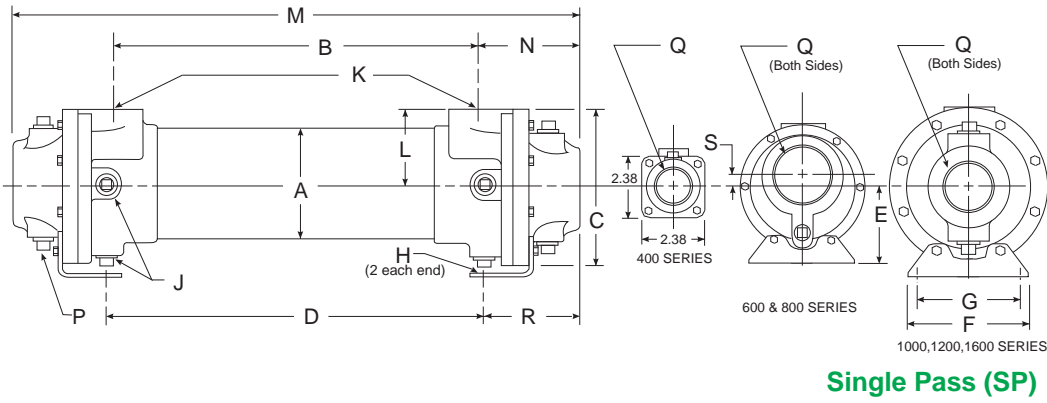

Model	M	N	P NPT	Q NPT	R	S
STA-408	11.00	2.38	-	1.00	-	-
STA-608	11.25					
STA-614	17.25	2.56	(2)	1.50	3.06	0.38
STA-624	27.25		.38			
STA-814	18.00					
STA-824	28.50	3.44	(2)	2.00	2.56	0.50
STA-836	40.00		.38			
STA-1014	18.50					
STA-1024	28.50	3.69	(4)	2.50	3.38	-
STA-1036	40.50		.38			
STA-1224	29.25					
STA-1236	41.25					
STA-1248	53.25	4.25	(4)	3.00	3.75	-
STA-1260	65.25					
STA-1272	77.25					
STA-1624	31.25					
STA-1636	43.25					
STA-1648	55.25	6.52	(4)	4.00	5.25	-
STA-1660	67.25		.50			
STA-1672	79.25					
STA-1684	91.25					

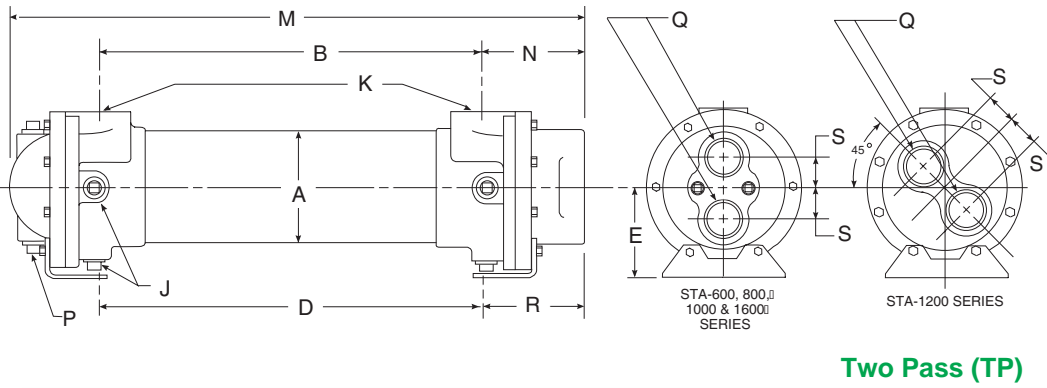

Model	M	N	P NPT	Q NPT	R	S
STA-608	10.75					
STA-614	16.75	2.44	(2)	1.00	2.94	1.00
STA-624	26.75		.38			
STA-814	17.62					
STA-824	27.62	3.44	(2)	1.25	2.56	1.19
STA-836	39.62		.38			
STA-1014	18.50					
STA-1024	28.50	3.69	(2)	1.50	3.50	1.50
STA-1036	40.50		.38			
STA-1224	28.75					
STA-1236	40.75					
STA-1248	52.75	4.25	(2)	2.00	3.75	1.56
STA-1260	64.75		.38			
STA-1272	76.75					
STA-1624	30.50					
STA-1636	42.50					
STA-1648	54.50	6.00	(2)	2.50	5.25	2.25
STA-1660	66.50		.50			
STA-1672	78.50					
STA-1684	90.50					

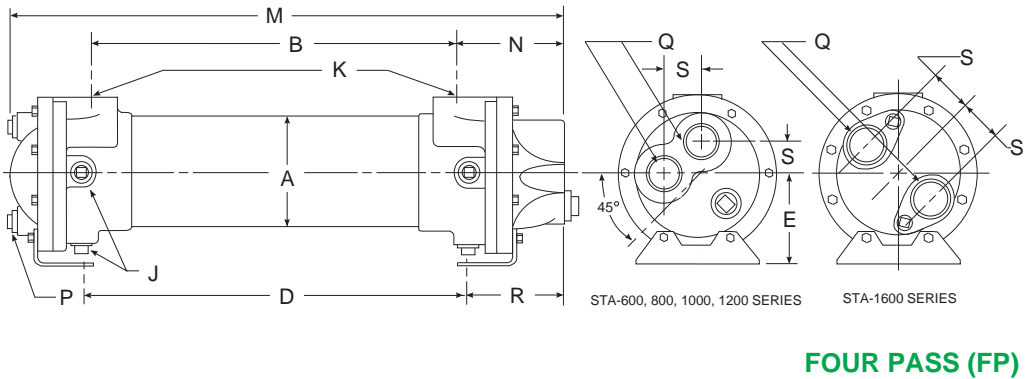

Model	M	N	P NPT	Q NPT	R	S
STA-608	10.88					
STA-614	16.88	2.44	(2)	.75	2.81	1.00
STA-624	26.88		.38			
STA-814	17.62					
STA-824	27.62	3.44	(2)	.75	2.56	1.06
STA-836	39.62		.38			
STA-1014	18.50					
STA-1024	28.50	3.80	(3)	1.00	3.25	1.69
STA-1036	40.50		.38			
STA-1224	29.50					
STA-1236	41.50					
STA-1248	53.50	4.56	(3)	1.50	3.75	2.00
STA-1260	65.50		.50			
STA-1272	77.50					
STA-1624	30.75					
STA-1636	42.75					
STA-1648	54.75	6.08	(4)	2.00	5.25	2.62
STA-1660	66.75		.50			
STA-1672	78.75					
STA-1684	90.75					

## COMMON DIMENSIONS & WEIGHTS

Model	A	B	C	D	E	F	G	H	J NPT	K	L	Approx. Weight	Model
STA-408	2.125	6.25	-	-	-	-	-	-	-	.50	1.69	7	STA-408
STA-608		6.12		5.12						1.00	2.44	12	STA-608
STA-614	3.125	12.12	4.19	11.12	2.44	3.50	2.50	.38øx.88	(2)			16	STA-614
STA-624		22.12		21.12					.25			20	STA-624
STA-814		11.12		12.88						1.50	3.12	37	STA-814
STA-824	4.125	21.12	5.88	22.88	3.50	4.75	3.50	.50øx1.62	(6)			47	STA-824
STA-836		33.12		34.88					.38			67	STA-836
STA-1014		11.12		11.75						1.50	3.62	45	STA-1014
STA-1024	5.125	21.12	6.50	21.75	3.75	5.00	4.00	.50øx.88	(6)			60	STA-1024
STA-1036		33.12		33.75					.38			82	STA-1036
STA-1224		20.50		21.50								90	STA-1224
STA-1236		32.50		33.50								110	STA-1236
STA-1248	6.125	44.50	7.50	45.50	4.12	6.00	5.00	.50øx.88	(6)	2.00	4.25	130	STA-1248
STA-1260		56.50		57.50					.38			150	STA-1260
STA-1272		68.50		69.50								180	STA-1272
STA-1624		19.00		20.50								160	STA-1624
STA-1636		31.00		32.50								185	STA-1636
STA-1648		43.00		44.50						3.00	5.62	205	STA-1648
STA-1660	8.00	55.00	9.75	56.50	5.38	8.25	7.00	.62øx1.12	(6)			235	STA-1660
STA-1672		67.00		68.50					.38			280	STA-1672
STA-1684		79.00		80.50								320	STA-1684

note: AIHTI reserves the right to make reasonable design changes without notice.



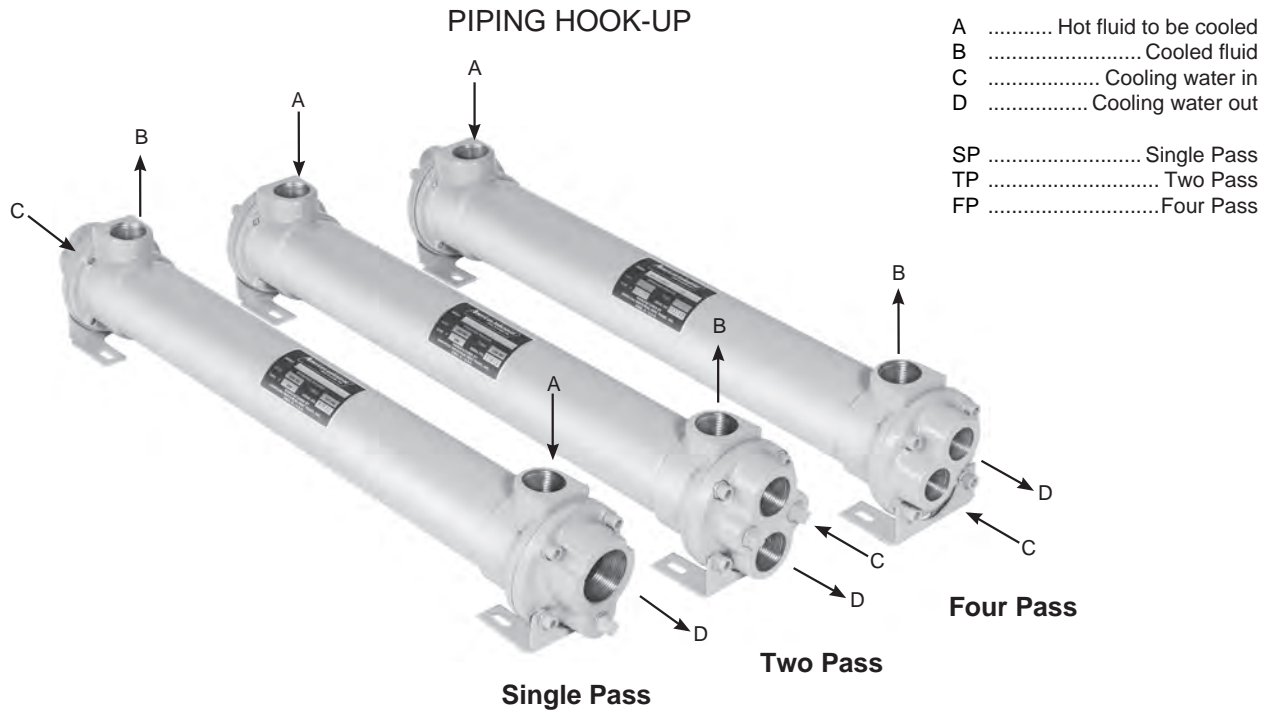

## Receiving / Installation

a) Inspect unit for any shipping damage before uncrating. Indicate all damages to the trucking firms' delivery person, and mark it on the receiving bill before accepting the freight. Make sure that there is no visible damage to the outside surface of the heat exchanger. The published weight information located in this brochure is approximate. True shipment weights are determined at the time of shipping and may vary. Approximate weight information published herein is for engineering approximation purposes and should not be used for exact shipping weight. Since the warranty is based upon the unit date code located on the model identification tags, removal or manipulation of the identification tags will void the manufacturer's warranty.

b) When handling the shell & tube heat exchanger, special care should be taken to avoid dropping the unit since mishandling could cause the heat exchanger to crack and leak externally. Mishandling of the unit is not covered under the manufacturer's warranty. All units are shipped with partial wood/corrugated cardboard containers for safe handling.

c) Storage: American Industrial heat exchangers are protected against the elements during shipment. If the heat exchanger cannot be installed and put into operation immediately upon receipt, certain precautions are required to prevent deterioration during storage. The responsibility for integrity of the heat exchanger(s) is assumed by the user. American Industrial will not be responsible for damage, corrosion, or other deterioration of the heat exchanger during transit or storage.

Proper storage practices are important when considering the high costs of repair or replacement, and the possible delays for items which require long lead times for manufacture. The following listed practices are provided solely as a convenience to the user, who shall make their own decision on whether to use all or any of them.

- 1) Heat exchangers not to be placed in immediate service, require precautionary measures to prevent corrosion or contamination.
- 2) Heat exchangers made of ferrous materials, may be pressure-tested using compressed air at the factory. Residual oil coating on the inside surfaces of the heat exchanger(s) as a result of flushing does not discount the possibility of internal corrosion. Upon receipt, fill the heat exchanger(s) with the appropriate grade of oil or apply a corrosion preventing inhibitor for storage.
- 3) Corrosion protection compounds for interior surfaces for long term storage or other applications are applied solely at the request of customers. Upon request, American Industrial can provide a customer approved corrosion preventative if available when included in the

original purchase order specifications.

- 4) Remove all dirt, water, ice, or snow and wipe dry before moving heat exchanger(s) into storage. Heat exchangers are generally shipped empty, open drain plugs to remove any accumulated condensation moisture, then reseal. Accumulation of moisture usually indicates corrosion has already started and remedial action should be taken.
- 5) Store in a covered, environmentally stable area. The ideal storage environment for heat exchangers is in a dry, low-humidity atmosphere which is sealed to prevent the entry of blowing dust, rain, or snow. Maintain in atmospheric temperatures between 70°F and 105°F (Large temperature swings may cause condensation and moisture to form on steel components, threads, shell, etc...) Use thermometers and humidity indicators and maintain the atmosphere at 40% relative humidity, or lower.

d) Standard Enamel Coating: American Industrial provides its standard products with a normal base coat of oil base air cure enamel paint. The enamel paint is applied as a temporary protective and esthetic coating prior to shipment. While the standard enamel coating is durable, American Industrial does not warranty it as a long-term finish coating. It is strongly suggested that a more durable final coating be applied after installation or prior to long-term storage in a corrosive environment to cover any accidental scratches, enhance esthetics, and further prevent corrosion. It is the responsibility of the customer to provide regular maintenance against chips, scratches, etc... and regular touch up maintenance must be provided for long-term benefits and corrosion prevention.

e) Special Coatings: American Industrial offers as customer options, Air-Dry Epoxy, and Heresite (Air-Dry Phenolic) coatings at additional cost. American Industrial offers special coatings upon request, however American Industrial does not warranty coatings to be a permanent solution for any equipment against corrosion. It is the responsibility of the customer to provide regular maintenance against chips, scratches, etc... and regular touch up maintenance must be provided for long-term benefits and corrosion prevention.

f) American Industrial recommends that the equipment supplied should be installed by qualified personnel who have solid understanding of system design, pressure and temperature ratings, and piping assembly. Verify the service conditions of the system prior to applying any shell & tube heat exchanger. If the system pressure or temperature does not fall within the parameters on model rating tag located on the heat exchanger, contact our factory prior to installation or operation.

# AA & STA Series *installation & maintenance*

g) Plan the installation to meet the requirements indicated on the piping installation diagram as illustrated above. It is recommended to put the hot fluid to be cooled through the shell side and the cold fluid through the tube side. The indicated port assembly sequence in the diagram maximizes the performance, and minimizes the possibility of thermal shock. In instances where the fluids are required to be reversed, *hot fluid in the tubes and cold fluid in the shell* the heat exchanger will work with reduced performance. Installation may be vertical or horizontal or a combination thereof. However, the installation must allow for complete draining of the heat exchanger regardless of Single Pass, Two Pass, or four pass construction. Complete drainage is important to prevent the heat exchanger from freezing, over-heating of a fluid, or mineral deposit buildup.

For fixed bundle heat exchangers, provide sufficient clearance at one end to allow for the removal or replacement of tubes. On the opposite end, provide enough space to allow removal of the complete bonnet to provide sufficient clearance to permit tube rolling and cleaning. Allow accessible room for scheduled cleaning as needed. Include thermometer wells and pressure gauge pipe ports in piping to and from the heat exchanger located as close to the heat exchanger as possible. For more information please contact American Industrial.

h) It is recommended to use flexible hose wherever possible to reduce vibration and allow slight movement. However, hoses are not required. Hydraulic carrying lines should be sized to handle the appropriate flow and to meet system pressure drop requirements based upon the systems parameters, and not based upon the units supply and return connection size. We recommend that a low cracking pressure direct acting relief valve be installed at the heat exchanger inlet to protect it from pressure spikes by bypassing oil in the event the system experiences a high flow surge. If preventative filtration is used it should be located ahead of the cooler on both shell and tube side to catch any scale or sludge from the system before it enters the cooler. Failure to install filters ahead of the heat exchanger could lead to possible heat exchanger failure due to high pressure if the system filters plug.

i) Standard shell & tube coolers are built with a rolled tube-sheet construction. However, the differential operating temperature between the entering shell side fluid and the entering tube side fluid should not exceed 150°F. If this condition exists, a severe thermal shock could occur leading to product failure and mixing of the fluids. For applications with a differential temperatures of 150°F or more, we recommend using a series with a floating tube-sheet, u-tube, or expansion joint to reduce the potential for the effects of thermal shock.

j) Water requirements vary from location to location. If the source of cooling water is from other than a municipal water supply, it is recommended that a water strainer be installed ahead of the heat exchanger to prevent dirt and debris from entering and clogging the flow passages. If a water modulating valve is used it is recommended to be installed at the inlet to the cooler to regulate the water flow.

k) For steam service, or other related applications, please consult our engineering department for additional information.

## Maintenance

a) Inspect the heat exchanger for loosened bolts, connections, rust spots, corrosion, and for internal or external fluid leakage. Any corroded surfaces should be cleaned and recoated with paint.

b) **Shell side:** In many cases with clean hydraulic system oils it will not be necessary to flush the interior of the shell side of the cooler. In circumstances where the quality of hydraulic fluid is in question, the shell side should be disconnected and flushed on a yearly basis with a clean flushing oil/solvent to remove any sludge that has been deposited. For severe cases where the unit is plugged and cannot be flushed clean with solvent, the heat exchanger should be replaced to maintain the proper cooling performance.

c) **Tube side:** In many cases it will be necessary to clean the tube side of the heat exchanger due to poor fluid quality, debris, calcium deposits, corrosion, mud, sludge, seaweed, etc.... To clean the tube side, flush with clean water or any good quality commercial cleaner that does not attack

the particular material of construction. With straight tube heat exchangers you can use a rod to carefully push any debris out of the tubes.

d) **Zinc anodes** are normally used to reduce the risk of failure due to electrolysis. Zinc anodes are a sacrificial component designed to wear and dissolve through normal use. Normally, zinc anodes are applied to the water supply side of the heat exchanger. Depending upon the amount of corrosive action, one, two, three, or more anodes can be applied to help further reduce the risk of failure. American Industrial Heat Transfer, Inc. offers zinc anodes as an option, to be specified and installed at the request of our customers. It is the responsibility of the customer to periodically check and verify the condition of the zinc anode and replace it as needed.

Applications vary due to water chemical makeup and quality, material differences, temperature, flow rate, piping arrangements, and machine grounding. For those reasons, zinc anodes do not follow any scheduled factory predetermined maintenance plan moreover they must be checked routinely by the customer, and a maintenance plan developed based upon the actual wear rate.

If substantial wear occurs or zinc dissolves without replacement, premature failure or permanent damage may occur to the heat exchanger. American Industrial does not warranty customer applications. It is the responsibility of the customer to verify and apply the proper system materials of construction and overall system requirements. Failures resulting from properly applied or misapplied use of zinc anode(s) into non-specified or specified applications will be the sole responsibility of the customer.

e) A routine maintenance schedule should be developed and adjusted to meet your systems requirements based upon water quality, etc.... Failure to regularly maintain and clean your heat exchanger can result in a reduction in operational performance and life expectancy.

*Note: Since applications can vary substantially, the installation and maintenance information contained in this catalog should be used as a basic guideline. The safe installation, maintenance, and use of any American Industrial Heat Transfer, Inc. heat exchanger are solely the responsibility of the user.*

