

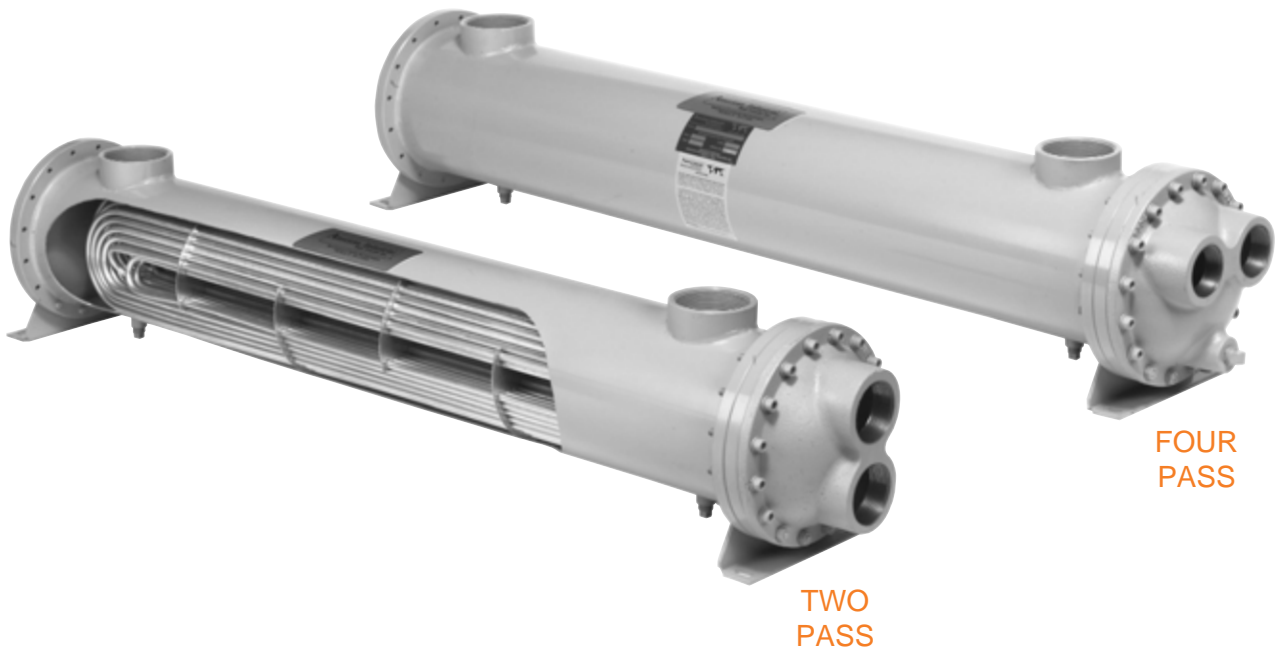

UCS & URCS SERIES



U-TUBE FIXED & REMOVEABLE BUNDLE

HEAT EXCHANGERS

- Removable tube bundle.
- Operating pressure for tubes 150 PSI.
- Operating pressure for shell 250 PSI.
- Operating temperature 400 °F.
- Can be customized to fit your needs.
- Cools: Fluid power systems, rock crushers, presses, shears, lubrication equipment for paper machinery, gear drives, marine transmissions, etc.



UCS SERIES

U-tube heat exchangers with fixed tube bundle for fluids with high differential inlet temperatures or where tube bundle requires removal. Normally applied when the differential temperature between the hot fluid entering and the cooling fluid entering is 150°F or greater. U-tube design allows tubing to freely expand and contract independently of the shell. Welded outer shell construction made of carbon steel. Sizes from 3" to 10" diameters. Standard two and four pass units available. Optional 90/10 copper nickel, stainless steel, and carbon steel tube. Can be modified to meet your requirements.



URCS SERIES

U-tube heat exchangers with removeable tube bundle for fluids with high differential inlet temperatures. Normally applied when the differential temperature between the hot fluid entering and the cooling fluid entering is 150°F or greater. U-tube design allows tubing to freely expand and contract independently of the shell. Welded outer shell construction made of carbon steel. Sizes from 3" to 10" diameters. Standard two and four pass units available. Optional 90/10 copper nickel, stainless steel, and carbon steel tube. Can be modified to meet your requirements.



SRCS SERIES

Strait tube heat exchangers with removeable tube bundle for fluids with high differential inlet temperatures or in applications where tube bundle requires removal. Normally applied when the differential temperature between the hot fluid entering and the cooling fluid entering is 150°F or greater. Strait tube design allows tubing to freely expand and contract independently of the shell. Welded outer shell construction made of carbon steel. Sizes from 6" to 20" diameters. Standard one and two pass units available. Optional 90/10 copper nickel, stainless steel, and carbon steel tube. Can be modified to meet your requirements.

(See Page 71)



AOCH SERIES *with electric drive*

Industrial air-cooled oil coolers, high performance six row rolled or brazed tube industrial series heat exchangers with direct electric drive cooling fan, OSHA guard, and air directing louvers. Rated operating temperature of 400°F at 300 PSIG. Services standard flow rates from 4 to 250 GPM. Thermal capacity up to 210 hp (157Kw). NPT, flange, or SAE straight thread port connections. Optional built-in bypass relief valve 30 PSI or 65 PSI. Can be modified to meet your requirements. Suitable for most hydraulic oils, lubrications oils, synthetic compressor oils, ethylene glycol, and many other fluids compatible with listed material.

In applications where water is not available for cooling (see page 145)

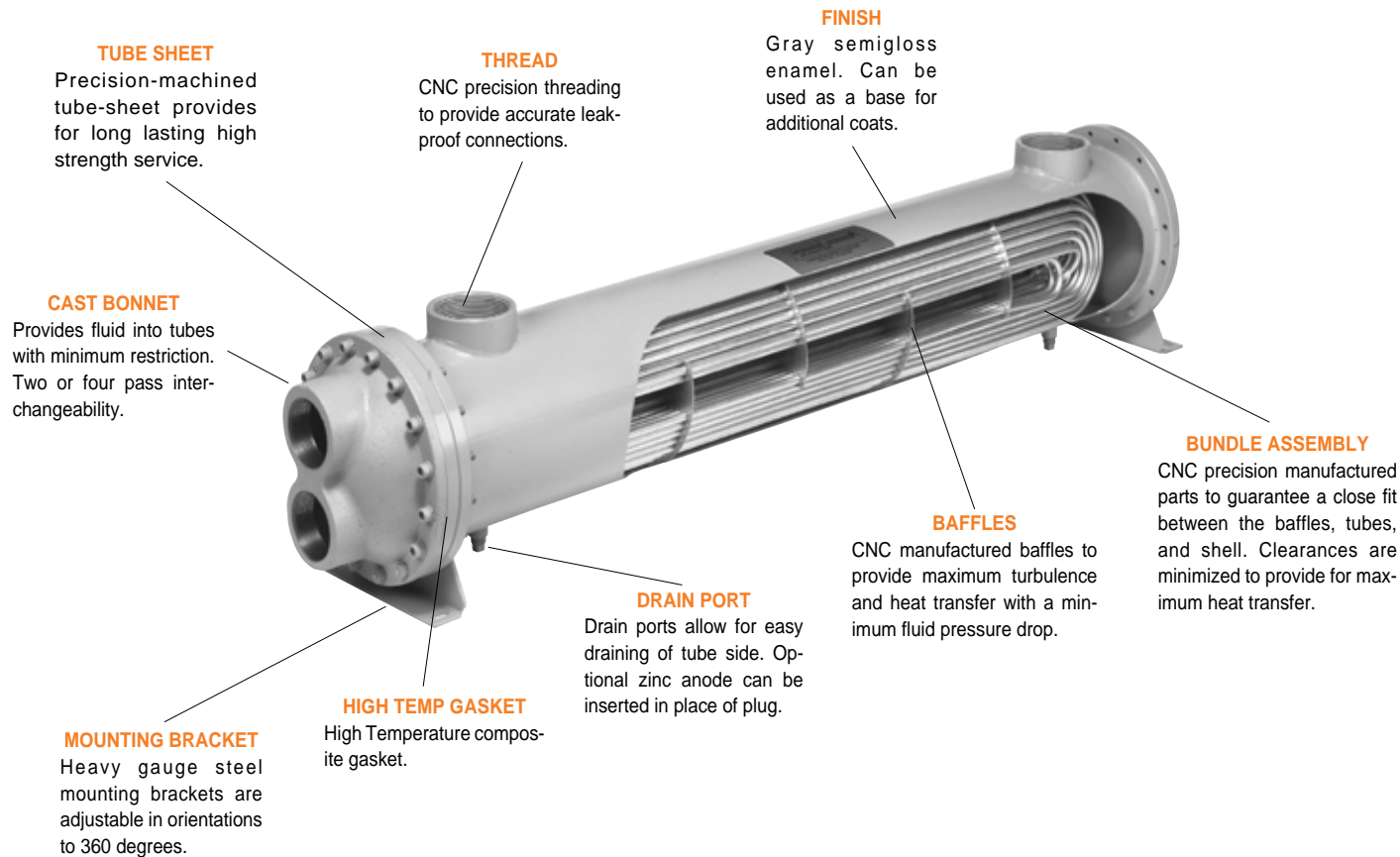

UNIT CODING

Example Model

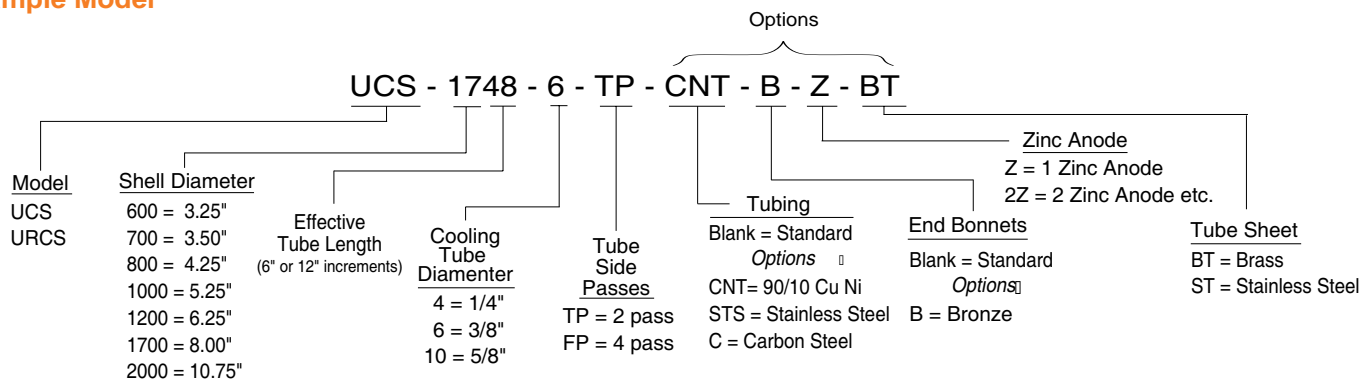

STANDARD CONSTRUCTION MATERIALS & RATINGS

Standard Model	UCS / URCS	Options	Standard Unit Ratings
Shell	Steel	Stainless Steel	Operating Pressure Tubes 150 psig Operating Pressure Shell 250 psig Operating Temperature 400 °F
Tubes	Copper	90/10 Cu. Ni. / Stainless Steel	
Baffles	Steel	Brass / Stainless Steel	
Tube Sheet	Steel	Brass / Stainless Steel	
End Bonnets	Cast Iron	Stainless Steel	
Mounting Brackets	Steel	Stainless Steel	
Gasket	High Temperature Gasket	Hypalon / Viton / EPR	

note: AIHTI reserves the right to make reasonable design changes without notice.

UCS & URCS Series selection

STEP 1: Calculate the heat load

The heat load in BTU/HR or (Q) can be derived by using several methods. To simplify things, we will consider general specifications for hydraulic system oils and other fluids that are commonly used with shell & tube heat exchangers.

Terms			
GPM	= Gallons Per Minute	Kw	= Kilowatt (watts x 1000)
CN	= Constant Number for a given fluid	T _{in}	= Hot fluid entering temperature in °F
ΔT	= Temperature differential across the potential	T _{out}	= Hot fluid exiting temperature in °F
PSI	= Pounds per Square Inch (pressure) of the operating side of the system	t _{in}	= Cold fluid temperature entering in °F
MHP	= Horsepower of the electric motor driving the hydraulic pump	t _{out}	= Cold fluid temperature exiting in °F
		Q	= BTU / HR

For example purposes, a 2,000 HP gear box lubrication system is provided with a flow of 80 GPM. The temperature differential of the oil entering the pump @ 200°F vs exiting the system @ 230°F is about 30.0°F. Though our return line pressure is below 100 psi, calculate the system heat load potential (Q) based upon the measured ΔT and the flow rate or by using the overall efficiency in our case 90%.

To derive the required heat load (Q) to be removed by the heat exchanger, apply the following. Note: The calculated heat load may differ slightly from one formula to the next. This is due to assumptions made when estimating heat removal requirements.

FORMULA	EXAMPLE
A) Q = GPM x CN x actual ΔT	A) Q = 80 x 210 x 30°F = 504,000 BTU/HR
B) Q = [(PSI x GPM) / 1714] x (v) x 2545	
C) Q = MHP x (v) x 2545	
D) Q = Kw to be removed x 3415	D) Q = 1,490 x (1 - 0.9) x 3415 = 508,835 BTU/HR
E) Q = HP x (1 - % efficiency) x 2545	E) Q = 2,000 x (1 - 0.9) x 2545 = 509,000 BTU/HR

Constant for a given fluid (CN)

- 1) Oil CN = 210
- 2) Water..... CN = 500
- 3) 50% E. Glycol..... CN = 450

STEP 2: Calculate the Mean Temperature Difference

When calculating the MTD you will be required to choose a liquid flow rate to derive the cold side ΔT. If the water flow is unknown, assume a number based on what is available. As a normal rule of thumb, for oil to water cooling a 2:1 oil to water ratio is used. For applications of water to water or 50 % Ethylene Glycol to water, a 1:1 ratio is common.

FORMULA	EXAMPLE
HOT FLUID ΔT Oil = $\frac{Q}{CN \times GPM}$	$\Delta T = \frac{504,000 \text{ BTU/hr (from step 1, item B)}}{210 \text{ CN} \times 80 \text{ GPM}} = 30^\circ\text{F} = \Delta T \text{ Rejected}$
COLD FLUID Δt Water = $\frac{BTU / hr}{CN \times GPM}$	$\Delta t = \frac{504,000 \text{ BTU/hr}}{500 \text{ CN} \times 40 \text{ GPM (for a 2:1 ratio)}} = 25.2^\circ\text{F} = \Delta T \text{ Absorbed}$
T _{in} = Hot Fluid entering temperature in degrees F	T _{in} = 125.3 °F
T _{out} = Hot Fluid exiting temperature in degrees F	T _{out} = 120.0 °F
t _{in} = Cold Fluid entering temperature in degrees F	t _{in} = 70.0 °F
t _{out} = Cold Fluid exiting temperature in degrees F	t _{out} = 74.5 °F
$\frac{T_{out} - t_{in}}{T_{in} - t_{out}} = \frac{S[\text{smaller temperature difference}]}{L[\text{larger temperature difference}]} = \left(\frac{S}{L}\right)$	$\frac{230^\circ\text{F} - 40^\circ\text{F} = 190^\circ\text{F}}{230^\circ\text{F} - 65.2^\circ\text{F} = 164.8^\circ\text{F}} = \left(\frac{S}{L}\right) = \frac{164.8^\circ\text{F}}{190^\circ\text{F}} = .867$

STEP 3: Calculate Log Mean Temperature Difference (LMTD)

To calculate the LMTD please use the following method;

L = Larger temperature difference from step 2
M = S/L number (LOCATED IN TABLE A).

L = 190°F
M = .933

LMTD_i = L x M

LMTD_i = 190 x .933 (FROM TABLE A) = **177.3**

To correct the LMTD_i for a multipass heat exchangers calculate **R** & **K** as follows:

FORMULA	EXAMPLE
$R = \frac{T_{in} - T_{out}}{t_{out} - t_{in}}$	$R = \frac{230^\circ\text{F} - 200^\circ\text{F}}{65.2^\circ\text{F} - 40^\circ\text{F}} = \frac{30^\circ\text{F}}{25.2^\circ\text{F}} = \{1.19=R\}$
$K = \frac{t_{out} - t_{in}}{T_{in} - t_{in}}$	$K = \frac{65.2^\circ\text{F} - 40^\circ\text{F}}{230^\circ\text{F} - 40^\circ\text{F}} = \frac{25.2^\circ\text{F}}{190^\circ\text{F}} = \{0.132=K\}$

Locate the correction factor CF_B
(FROM TABLE B)
LMTD_c = LMTD_i x CF_B
LMTD_c = 177.3 x 1 = **177.3**

STEP 4: Calculate the area required

$$\text{Required Area sq.ft.} = \frac{Q \text{ (BTU / HR)}}{\text{LMTD}_c \times U \text{ (FROM TABLE C)}} = \frac{504,000}{177.3 \times 100} = 28.5 \text{ sq.ft.}$$

STEP 5: Selection

a) From TABLE E choose the correct series size, baffle spacing, and number of passes that best fits your flow rates for both shell and tube side. Note that the tables suggest minimum and maximum information. Try to stay within the 20-80 percent range of the indicated numbers.

Example

Oil Flow Rate = 80 GPM = Series Required from Table E = **1200 Series**
 Baffle Spacing from Table E = **4**
 Water Flow Rate = 40 GPM = Passes required in 1200 series = **4 (FP)**

b) From TABLE D choose the heat exchanger model size based upon the sq.ft. or surface area in the series size that will accommodate your flow rate.

Example

Required Area = 28.5sq.ft Closest model required based upon sq.ft. & series = **UCS - 1248 - 4 - 6 - FP**

If you require a computer generated data sheet for the application, or if the information that you are trying to apply does not match the corresponding information, please contact our engineering services department for further assistance.

TABLE A- FACTOR M/LMTD = L x M

S/L	M	S/L	M	S/L	M	S/L	M
.01	.215	.25	.541	.50	.721	.75	.870
.02	.251	.26	.549	.51	.728	.76	.864
.03	.277	.27	.558	.52	.734	.77	.879
.04	.298	.28	.566	.53	.740	.78	.886
		.29	.574	.54	.746	.79	.890
.05	.317	.30	.582	.55	.753	.80	.896
.06	.334	.31	.589	.56	.759	.81	.902
.07	.350	.32	.597	.57	.765	.82	.907
.08	.364	.33	.604	.58	.771	.83	.913
.09	.378	.34	.612	.59	.777	.84	.918
.10	.391	.35	.619	.60	.783	.85	.923
.11	.403	.36	.626	.61	.789	.86	.928
.12	.415	.37	.634	.62	.795	.87	.934
.13	.427	.38	.641	.63	.801	.88	.939
.14	.438	.39	.648	.64	.806	.89	.944
.15	.448	.40	.655	.65	.813	.90	.949
.16	.458	.41	.662	.66	.818	.91	.955
.17	.469	.42	.669	.67	.823	.92	.959
.18	.478	.43	.675	.68	.829	.93	.964
.19	.488	.44	.682	.69	.836	.94	.970
.20	.497	.45	.689	.70	.840	.95	.975
.21	.506	.46	.695	.71	.848	.96	.979
.22	.515	.47	.702	.72	.852	.97	.986
.23	.524	.48	.709	.73	.858	.98	.991
.24	.533	.49	.715	.74	.864	.99	.995

TABLE D- Surface Area in Sq. ft. for UCS & URCS Series

Model Number Code	1/4" O.D. Tubing Code 4	Model Number Code	3/8" O.D. Tubing Code 6	5/8" O.D. Tubing Code 10
614	3.6	1024	11.0	6.5
624	6.8	1036	16.5	9.8
630	7.8	1048	22.0	13.0
636	9.4	1224	17.3	9.1
		1236	25.9	13.7
		1248	34.5	18.3
		1260	43.2	22.9
712	3.4	1272	51.8	27.5
718	5.1	1284	60.5	32.0
724	6.8	1724	32.2	17.0
730	8.5	1736	48.3	25.5
		1748	64.4	34.0
736	10.2	1760	80.5	42.5
		1772	96.6	51.0
		1784	112.7	59.5
814	7.0	2036	80.1	41.2
824	12.0	2048	106.8	55.0
830	15.1	2060	133.5	68.7
		2072	160.2	82.5
836	19.2	2084	186.9	96.2

TABLE B- LMTD correction factor for Multipass Exchangers

	.05	.1	.15	.2	.25	.3	.35	.4	.45	.5	.6	.7	.8	.9	1.0
.2	1	1	1	1	1	1	1	.999	.993	.984	.972	.942	.908	.845	.71
.4	1	1	1	1	1	1	.994	.983	.971	.959	.922	.855	.70		
.6	1	1	1	1	1	.992	.980	.965	.948	.923	.840				
.8	1	1	1	1	.995	.981	.965	.945	.916	.872					
1.0	1	1	1	1	.988	.970	.949	.918	.867	.770					
2.0	1	1	.977	.973	.940	.845	.740								
3.0	1	1	.997	.933	.835										
4.0	1	.993	.950	.850											
5.0	1	.982	.917												
6.0	1	.968	.885												
8.0	1	.930													
10.0	.996	.880													
12.0	.985	.720													
14.0	.972														
16.0	.958														
18.0	.940														
20.0	.915														

TABLE E- Flow Rate for Shell & Tube

Shell dia. Code	Max. Liquid Flow - Shell Side					Liquid Flow - Tube Side			
	Baffle Spacing					TP		FP	
	1.5	2	3	4	6	Min.	Max.	Min.	Max.
600	15	20	25	30	-	3.5	24	2	12
800	20	34	45	60	-	4.5	38	3	21
1000	30	36	50	65	-	10	70	5	37
1200	45	50	70	100	125	15	112	7.5	56
1700	50	65	100	140	220	29	180	14	90
2000	-	-	140	190	320	45	320	25	160

TABLE C

U	TUBE FLUID	SHELL FLUID
400	Water	Water
350	Water	50% E. Glycol
100	Water	Oil
300	50% E. Glycol	50% E. Glycol
90	50% E. Glycol	Oil

UCS Series *dimensions*

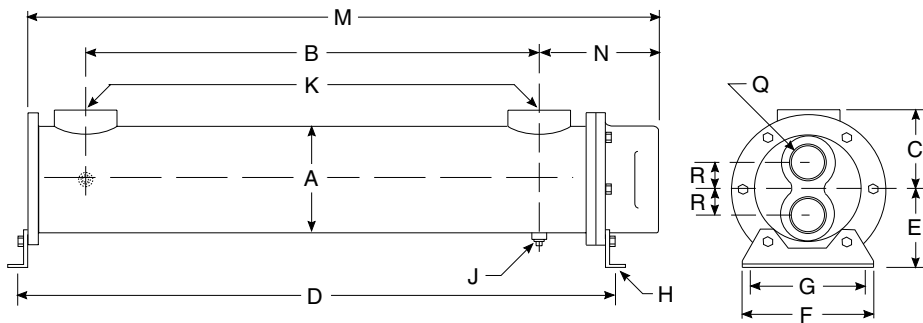

TWO PASS (TP)

Model	M	N	Q NPT	R
UCS-614	17.79			
UCS-624	27.79	3.70	1.00	1.00
UCS-630	33.79			
UCS-636	39.79			
UCS-712	16.56			
UCS-718	22.56	4.85	1.00	.88
UCS-724	28.56			
UCS-730	34.56			
UCS-736	40.56			
UCS-814	18.44			
UCS-824	28.44	4.82	1.25	1.06
UCS-830	34.44			
UCS-836	40.44			

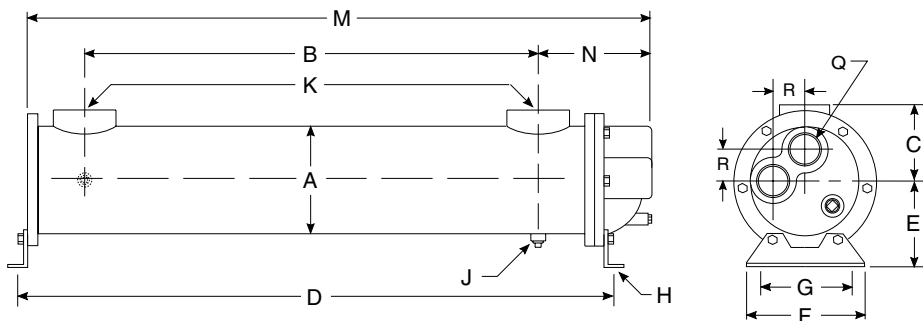

UCS-600, UCS-800

FOUR PASS (FP)

Model	M	N	Q NPT	R
UCS-614	17.78			
UCS-624	27.78	3.68	.75	1.00
UCS-630	33.78			
UCS-636	39.78			
UCS-712	16.53			
UCS-718	22.53	4.82	.75	
UCS-724	28.53			
UCS-730	34.53			
UCS-736	40.53			
UCS-814	18.44			
UCS-824	28.44	4.81	.75	1.25
UCS-830	34.44			
UCS-836	40.44			

COMMON DIMENSIONS

Model	A	B	C	D	E	F	G	H	J NPT	K NPT	Weight	Model
UCS-614		10.0		18.38							17	UCS-614
UCS-624	3.25	20.0	2.63	28.38	2.75	4.18	1.62	.39 x 1.00 Thru Slot	.25 (2x)	1.00	24	UCS-624
UCS-630		26.0		34.38							30	UCS-630
UCS-636		32.0		40.38							36	UCS-636
UCS-712		7.0		16.75							18	UCS-712
UCS-718	3.75	13.0	2.88	22.75	3.62	5.25	1.50	.39 x 1.00 Thru Slot	.25 (2x)	1.50	20	UCS-718
UCS-724		19.0		28.75							22	UCS-724
UCS-730		25.0		34.75							24	UCS-730
UCS-736		31.0		40.75							26	UCS-736
UCS-814		9.0		19.09							32	UCS-814
UCS-824	4.25	19.0	3.12	29.09	3.50	4.25	1.75	.39 x 1.00 Thru Slot	.25 (2x)	1.50	41	UCS-824
UCS-830		25.0		35.09							47	UCS-830
UCS-836		31.0		41.09							53	UCS-836

note: AIHTI reserves the right to make reasonable design changes without notice.

UCS Series *dimensions*

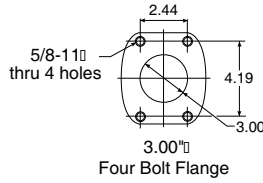
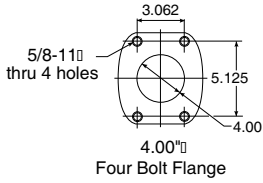
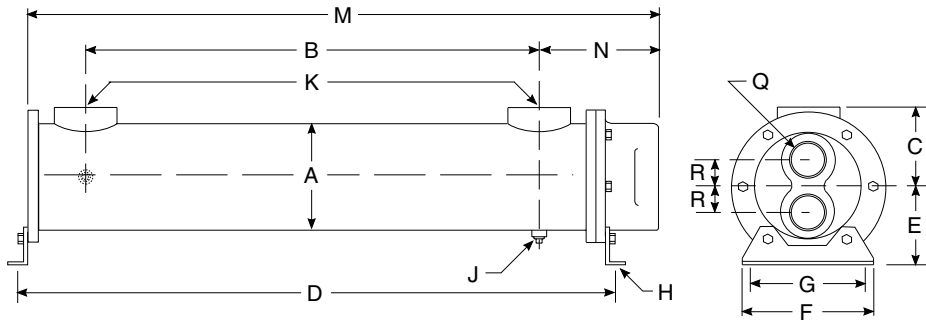

TWO PASS (TP)

Model	M	N	Q NPT	R
UCS-1024	28.88			
UCS-1036	40.88	4.94	1.50	1.19
UCS-1048	52.88			
UCS-1224	29.17			
UCS-1236	41.17	5.35	2.00	1.44
UCS-1248	53.17			
UCS-1260	65.17			
UCS-1272	77.17			
UCS-1284	89.17			
UCS-1724	30.13			
UCS-1736	42.13			
UCS-1748	54.13	7.31	2.50	1.88
UCS-1760	66.13			
UCS-1772	78.13			
UCS-1784	90.13			
UCS-2036	43.91			
UCS-2048	55.91			
UCS-2060	67.91	9.57	3.00	2.50
UCS-2072	79.91			
UCS-2084	91.91			

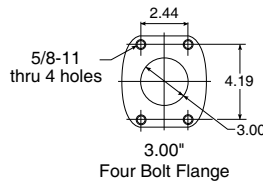
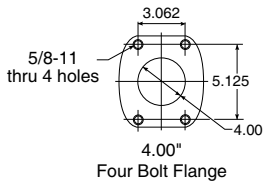
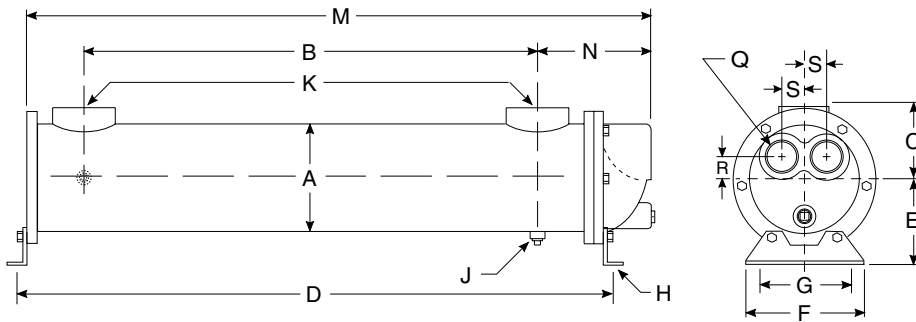

FOUR PASS (FP)

Model	M	N	Q NPT	R	S
UCS-1024	29.21				
UCS-1036	41.21	5.27	1.00	.75	1.19
UCS-1048	53.21				
UCS-1224	29.58				
UCS-1236	41.58	5.76	1.50	1.06	1.44
UCS-1248	53.58				
UCS-1260	65.58				
UCS-1272	77.58				
UCS-1284	84.58				
UCS-1724	29.78				
UCS-1736	41.78				
UCS-1748	53.78	6.96	2.00	1.38	1.88
UCS-1760	65.78				
UCS-1772	77.78				
UCS-1784	89.78				
UCS-2036	44.00				
UCS-2048	56.00				
UCS-2060	68.00	9.66	2.50	1.75	2.50
UCS-2072	80.00				
UCS-2084	92.00				

COMMON DIMENSIONS

Model	A	B	C	D	E	F	G	H	J NPT	K NPT	K SAE	Weight	Model
UCS-1024		19.00		29.13							#24	55.00	UCS-1024
UCS-1036	5.25	31.00	3.69	41.13	4.00	5.25	2.00	.44 x 1.00 thru slot	.375	1.50	1.875-12 SAE O-Ring	70.00	UCS-1036
UCS-1048		43.00		53.13								85.00	UCS-1048
UCS-1224		18.25		29.59							#32	83.00	UCS-1224
UCS-1236		30.25		41.59								108.00	UCS-1236
UCS-1248	6.25	42.25	4.19	53.59	4.50	6.25	2.50	.44 x 1.00 thru slot	.375	2.00	2.50-12 SAE O-Ring	132.00	UCS-1248
UCS-1260		54.25		65.59								158.00	UCS-1260
UCS-1272		66.25		77.59								182.00	UCS-1272
UCS-1284		78.25		89.59								206.00	UCS-1284
UCS-1724		17.00		29.50								138.00	UCS-1724
UCS-1736		29.00		41.50								180.00	UCS-1736
UCS-1748	8.00	41.00	5.06	53.50	5.75	8.25	3.50	.44 x 1.00 thru slot	.375	3.00	3.0" Four Bolt Flange	219.00	UCS-1748
UCS-1760		53.00		65.50								258.00	UCS-1760
UCS-1772		65.00		77.50								300.00	UCS-1772
UCS-1784		77.00		89.50								342.00	UCS-1784
UCS-2036		28.50		42.63								620.00	UCS-2036
UCS-2048		40.50		54.63								670.00	UCS-2048
UCS-2060	10.75	52.50	6.88	66.63	8.00	11.50	5.00	.781 x 1.25 thru slot	.50	4.00	4.0" Four Bolt Flange	730.00	UCS-2060
UCS-2072		64.50		78.63								820.00	UCS-2072
UCS-2084		76.50		90.63								870.00	UCS-2084

note: AIHTI reserves the right to make reasonable design changes without notice.

URCS Series *dimensions*

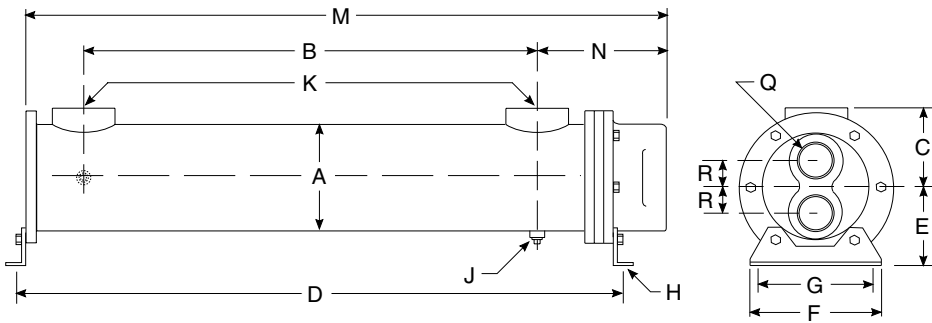

TWO PASS (TP)

Model	M	N	Q NPT	R
URCS-614	17.61			
URCS-624	27.61			
URCS-630	33.61	4.55	1.00	1.00
URCS-636	39.61			
URCS-712	16.63			
URCS-718	22.63			
URCS-724	28.63	5.66	1.00	.88
URCS-730	34.63			
URCS-736	40.63			
URCS-814	18.50			
URCS-824	28.50			
URCS-830	34.50	5.63	1.25	1.06
URCS-836	40.50			

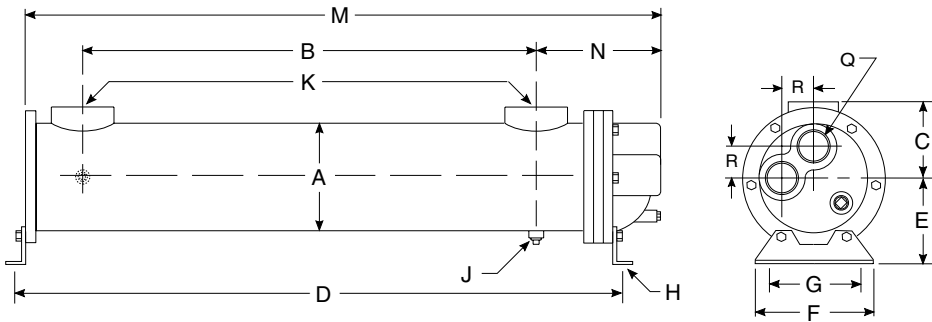

URCS-600, URCS-800

FOUR PASS (FP)

Model	M	N	Q NPT	R
URCS-614	17.59			
URCS-624	27.59			
URCS-630	33.59	4.49	.75	1.00
URCS-636	39.59			
URCS-712	16.60			
URCS-718	22.60			
URCS-724	28.60	5.63	.75	
URCS-730	34.60			
URCS-736	40.60			
URCS-814	18.50			
URCS-824	28.50			
URCS-830	34.50	5.62	.75	1.25
URCS-836	40.50			

COMMON DIMENSIONS

Model	A	B	C	D	E	F	G	H	J NPT	K NPT	Weight	Model
URCS-614		10.0		18.19							17	URCS-614
URCS-624	3.25	20.0		28.19	2.75	4.18	1.62	.39 x 1.00 Thru Slot	.25 (2x)	1.00	24	URCS-624
URCS-630		26.0	2.63	34.19							30	URCS-630
URCS-636		32.0		40.19							36	URCS-636
URCS-712		7.0		16.81							18	URCS-712
URCS-718	3.75	13.0		22.81	3.62	5.25	1.50	.39 x 1.00 Thru Slot	.25 (2x)	1.50	20	URCS-718
URCS-724		19.0	2.88	28.81							22	URCS-724
URCS-730		25.0		34.81							24	URCS-730
URCS-736		31.0		40.81							26	URCS-736
URCS-814		9.0		19.15							32	URCS-814
URCS-824	4.25	19.0		29.15	3.50	4.25	1.75	.39 x 1.00 Thru Slot	.25 (2x)	1.50	41	URCS-824
URCS-830		25.0	3.12	35.15							47	URCS-830
URCS-836		31.0		41.15							53	URCS-836

note: AIHTI reserves the right to make reasonable design changes without notice.

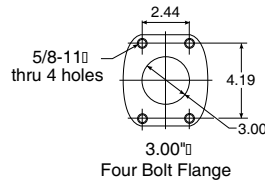
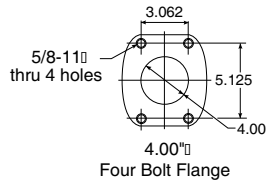
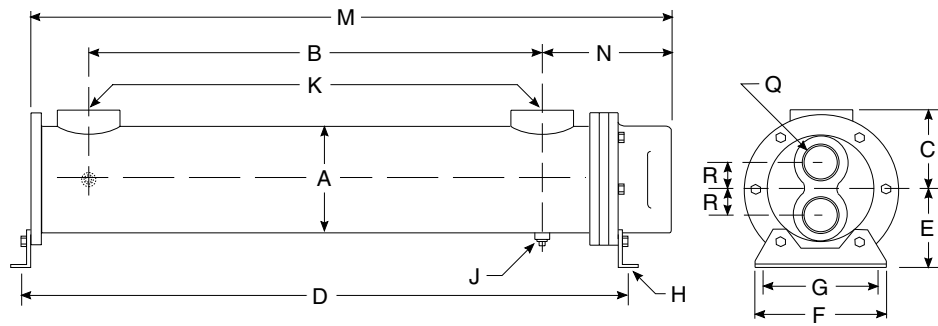

TWO PASS (TP)

Model	M	N	Q NPT	R
URCS-1024	28.88			
URCS-1036	40.88	5.75	1.50	1.19
URCS-1048	52.88			
URCS-1224	29.17			
URCS-1236	41.17			
URCS-1248	53.17	6.16	2.00	1.44
URCS-1260	65.17			
URCS-1272	77.17			
URCS-1284	89.17			
URCS-1724	30.13			
URCS-1736	42.13			
URCS-1748	54.13	8.12	2.50	1.88
URCS-1760	66.13			
URCS-1772	78.13			
URCS-1784	90.13			
URCS-2036	43.91			
URCS-2048	55.91			
URCS-2060	67.91	10.78	3.00	2.50
URCS-2072	79.91			
URCS-2084	91.91			

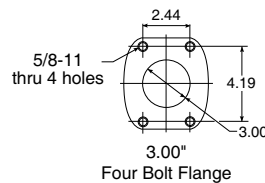
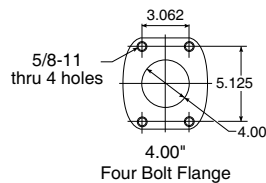
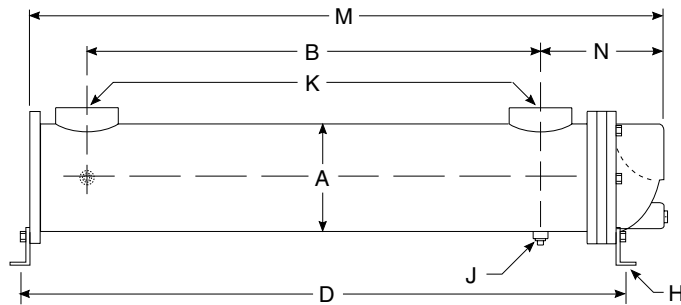

FOUR PASS (FP)

Model	M	N	Q NPT	R	S
URCS-1024	29.21				
URCS-1036	41.21	6.08	1.00	.75	1.19
URCS-1048	53.21				
URCS-1224	29.58				
URCS-1236	41.58				
URCS-1248	53.58	6.57	1.50	1.06	1.44
URCS-1260	65.58				
URCS-1272	77.58				
URCS-1284	84.58				
URCS-1724	29.78				
URCS-1736	41.78				
URCS-1748	53.78	7.77	2.00	1.38	1.88
URCS-1760	65.78				
URCS-1772	77.78				
URCS-1784	89.78				
URCS-2036	44.00				
URCS-2048	56.00				
URCS-2060	68.00	10.78	2.50	1.75	2.50
URCS-2072	80.00				
URCS-2084	92.00				

COMMON DIMENSIONS

Model	A	B	C	D	E	F	G	H	J NPT	K NPT	K SAE	Weight	Model
URCS-1024		19.00		29.13							#24	55.00	URCS-1024
URCS-1036	5.25	31.00	3.69	41.13	4.00	5.25	4.00	.44 x 1.00 thru slot	.375	1.50	1.875-12 SAE O-Ring	70.00	URCS-1036
URCS-1048		43.00		53.13								85.00	URCS-1048
URCS-1224		18.25		29.59							#32	83.00	URCS-1224
URCS-1236		30.25		41.59								108.00	URCS-1236
URCS-1248	6.25	42.25	4.19	53.59	4.50	6.25	5.00	.44 x 1.00 thru slot	.375	2.00	2.50-12 SAE O-Ring	132.00	URCS-1248
URCS-1260		54.25		65.59								158.00	URCS-1260
URCS-1272		66.25		77.59								182.00	URCS-1272
URCS-1284		78.25		89.59								206.00	URCS-1284
URCS-1724		17.00		29.50							3.0"	138.00	URCS-1724
URCS-1736		29.00		41.50							Four Bolt Flange	180.00	URCS-1736
URCS-1748	8.00	41.00	5.06	53.50	5.75	8.25	7.00	.44 x 1.00 thru slot	.375	3.00		219.00	URCS-1748
URCS-1760		53.00		65.50								258.00	URCS-1760
URCS-1772		65.00		77.50								300.00	URCS-1772
URCS-1784		77.00		89.50								342.00	URCS-1784
URCS-2036		28.50		42.63							4.0"	620.00	URCS-2036
URCS-2048		40.50		54.63							Four Bolt Flange	670.00	URCS-2048
URCS-2060	10.75	52.50	6.88	66.63	8.00	11.50	10.00	.781 x 1.25 thru slot	.50	4.00		730.00	URCS-2060
URCS-2072		64.50		78.63								820.00	URCS-2072
URCS-2084		76.50		90.63								870.00	URCS-2084

note: AIHTI reserves the right to make reasonable design changes without notice.

UCS & URCS Series *installation & maintenance*

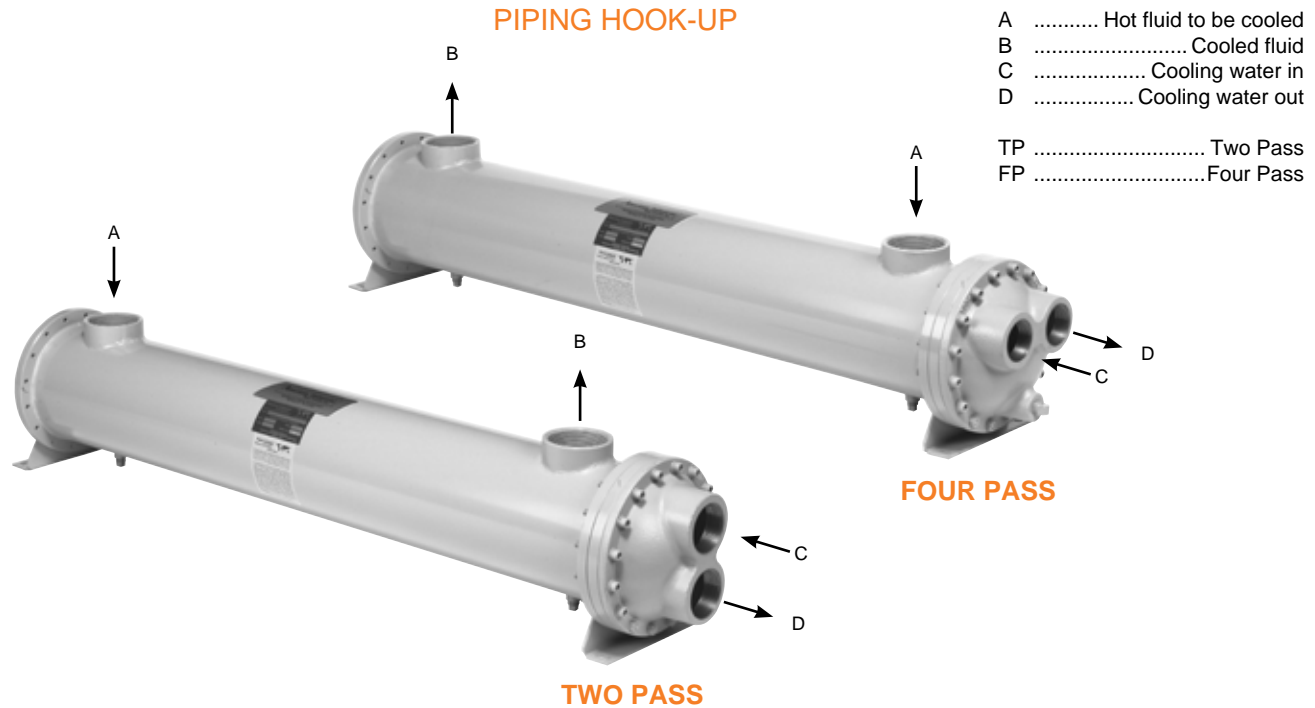

Receiving / Installation

a) Inspect unit for any shipping damage before uncrating. Indicate all damages to the trucking firms' delivery person, and mark it on the receiving bill before accepting the freight. Make sure that there is no visible damage to the outside surface of the heat exchanger. The published weight information located in this brochure is approximate. True shipment weights are determined at the time of shipping and may vary. Approximate weight information published herein is for engineering approximation purposes and should not be used for exact shipping weight. Since the warranty is based upon the unit date code located on the model identification tags, removal or manipulation of the identification tags will void the manufacturer's warranty.

b) When handling the shell & tube heat exchanger, special care should be taken to avoid dropping the unit since mishandling could cause the heat exchanger to crack and leak externally. Mishandling of the unit is not covered under the manufacturer's warranty. All units are shipped with partial wood/corrugated cardboard containers for safe handling.

c) Storage: American Industrial heat exchangers are protected against the elements during shipment. If the heat exchanger cannot be installed and put into operation immediately upon receipt, certain precautions are required to prevent deterioration during storage. The responsibility for integrity of the heat exchanger(s) is assumed by the user. American Industrial will not be responsible for damage, corrosion, or other deterioration of the heat exchanger during transit or storage.

Proper storage practices are important when considering the high costs of repair or replacement, and the possible delays for items which require long lead times for manufacture. The following listed practices are provided solely as a convenience to the user, who shall make their own decision on whether to use all or any of them.

- 1) Heat exchangers not to be placed in immediate service, require precautionary measures to prevent corrosion or contamination.
- 2) Heat exchangers made of ferrous materials, may be pressure-tested using compressed air at the factory. Residual oil coating on the inside surfaces of the heat exchanger(s) as a result of flushing does not discount the possibility of internal corrosion. Upon receipt, fill the heat exchanger(s) with the appropriate grade of oil or apply a corrosion preventing inhibitor for storage.
- 3) Corrosion protection compounds for interior surfaces for long term storage or other applications are applied solely at the

request of customers. Upon request, American Industrial can provide a customer approved corrosion preventative if available when included in the original purchase order specifications.

- 4) Remove all dirt, water, ice, or snow and wipe dry before moving heat exchanger(s) into storage. Heat exchangers are generally shipped empty, open drain plugs to remove any accumulated condensation moisture, then reseal. Accumulation of moisture usually indicates corrosion has already started and remedial action should be taken.
- 5) Store in a covered, environmentally stable area. The ideal storage environment for heat exchangers is in a dry, low-humidity atmosphere which is sealed to prevent the entry of blowing dust, rain, or snow. Maintain in atmospheric temperatures between 70°F and 105°F (Large temperature swings may cause condensation and moisture to form on steel components, threads, shell, etc...) Use thermometers and humidity indicators and maintain the atmosphere at 40% relative humidity, or lower.

d) Standard Enamel Coating: American Industrial provides its standard products with a normal base coat of oil base air cure enamel paint. The enamel paint is applied as a temporary protective and esthetic coating prior to shipment. While the standard enamel coating is durable, American Industrial does not warranty it as a long-term finish coating. It is strongly suggested that a more durable final coating be applied after installation or prior to long-term storage in a corrosive environment to cover any accidental scratches, enhance esthetics, and further prevent corrosion. It is the responsibility of the customer to provide regular maintenance against chips, scratches, etc... and regular touch up maintenance must be provided for long-term benefits and corrosion prevention.

e) Special Coatings: American Industrial offers as customer options, Air-Dry Epoxy, and Heresite (Air-Dry Phenolic) coatings at additional cost. American Industrial offers special coatings upon request, however American Industrial does not warranty coatings to be a permanent solution for any equipment against corrosion. It is the responsibility of the customer to provide regular maintenance against chips, scratches, etc... and regular touch up maintenance must be provided for long-term benefits and corrosion prevention.

f) American Industrial recommends that the equipment supplied should be installed by qualified personnel who have solid understanding of system design, pressure and temperature ratings, and piping assembly. Verify the service conditions of the system prior to applying any shell & tube heat exchanger. If the system pressure or temperature does not fall within the parameters on model

UCS & URCS Series *installation & maintenance*

rating tag located on the heat exchanger, contact our factory prior to installation or operation.

g) Plan the installation to meet the requirements indicated on the piping installation diagram as illustrated. It is recommended to put the hot fluid to be cooled through the shell side and the cold fluid through the tube side. The indicated port assembly sequence in the installation diagram maximizes the performance, and minimizes the possibility of thermal shock. In instances where the fluids are required to be reversed, *hot fluid in the tubes and cold fluid in the shell* the heat exchanger will work with reduced performance. Installation may be vertical or horizontal or a combination thereof. However, the installation must allow for complete draining of the heat exchanger regardless of two pass or four pass construction. Complete drainage is important to prevent the heat exchanger from freezing, over-heating of a fluid, or mineral deposit buildup. For removable bundle heat exchangers, provide sufficient clearance at the stationary tube-sheet end to allow for the removal of the tube bundle from the shell. Bonnet can be removed to aid in cleaning the tubes without disassembling the tube bundle. For more information please contact American Industrial.

h) It is recommended to use flexible hose wherever possible to reduce vibration and allow slight movement. However, hoses are not required. Hydraulic carrying lines should be sized to handle the appropriate flow and to meet system pressure drop requirements based upon the systems parameters, and not based upon the units supply and return connection size. We recommend that a low cracking pressure direct acting relief valve be installed at the heat exchanger inlet to protect it from pressure spikes by bypassing oil in the event the system experiences a high flow surge. If preventative filtration is used it should be located ahead of the cooler on both shell and tube side to catch any scale or sludge from the system before it enters the cooler. Failure to install filters ahead of the heat exchanger could lead to possible heat exchanger failure due to high pressure if the system filters plug.

i) Standard shell & tube coolers are built with a rolled tube-sheet construction. However, the differential operating temperature between the entering shell side fluid and the entering tube side fluid should not exceed 150°F. If this condition exists, a severe thermal shock could occur leading to product failure and mixing of the fluids. For applications with a differential temperatures of 150°F or more, we recommend using a series with a floating tube-sheet, u-tube, or expansion joint to reduce the potential for the effects of thermal shock.

j) Water requirements vary from location to location. If the source of cooling water is from other than a municipal water supply, it is recommended that a water strainer be installed ahead of the heat exchanger to prevent dirt and debris from entering and clogging the flow passages. If a water modulating valve is used it is recommended to be installed at the inlet to the cooler to regulate the water flow.

k) For steam service, or other related applications, please consult our engineering department for additional information.

Maintenance

a) Inspect the heat exchanger for loosened bolts, connections, rust spots, corrosion, and for internal or external fluid leakage. Any corroded surfaces should be cleaned and recoated with paint.

b) **Shell side:** In many cases with clean hydraulic system oils it will not be necessary to flush the interior of the shell side of the cooler. In circumstances where the quality of hydraulic fluid is in question, the shell side should be disconnected and flushed on a yearly basis with a clean flushing oil/solvent to remove any sludge that has been deposited. For severe cases where the unit is plugged and cannot be flushed clean with solvent, the heat exchanger should be replaced to maintain the proper cooling performance.

c) **Tube side:** In many cases it will be necessary to clean the tube side of the heat exchanger due to poor fluid quality, debris, calcium deposits, corrosion, mud, sludge, seaweed, etc.... To clean the tube side, flush with clean water or any good quality commercial cleaner that does not attack the particular material of construction.

With straight tube heat exchangers you can use a rod to carefully push any debris out of the tubes.

d) **Zinc anodes** are normally used to reduce the risk of failure due to electrolysis. Zinc anodes are a sacrificial component designed to wear and dissolve through normal use. Normally, zinc anodes are applied to the water supply side of the heat exchanger. Depending upon the amount of corrosive action, one, two, three, or more anodes can be applied to help further reduce the risk of failure. American Industrial Heat Transfer, Inc. offers zinc anodes as an option, to be specified and installed at the request our customers. It is the responsibility of the customer to periodically check and verify the condition of the zinc anode and replace it as needed.

Applications vary due to water chemical makeup and quality, material differences, temperature, flow rate, piping arrangements, and machine grounding. For those reasons, zinc anodes do not follow any scheduled factory predetermined maintenance plan moreover they must be checked routinely by the customer, and a maintenance plan developed based upon the actual wear rate.

If substantial wear occurs or zinc dissolves without replacement, premature failure or permanent damage may occur to the heat exchanger. American Industrial does not warranty customer applications. It is the responsibility of the customer to verify and apply the proper system materials of construction and overall system requirements. Failures resulting from properly applied or misapplied use of zinc anode(s) into non-specified or specified applications will be the sole responsibility of the customer.

e) A routine maintenance schedule should be developed and adjusted to meet your systems requirements based upon water quality, etc.... Failure to regularly maintain and clean your heat exchanger can result in a reduction in operational performance and life expectancy.

Note: Since applications can vary substantially, the installation and maintenance information contained in this catalog should be used as a basic guideline. The safe installation, maintenance, and use of any American Industrial Heat Transfer, Inc. heat exchanger are solely the responsibility of the user.

