

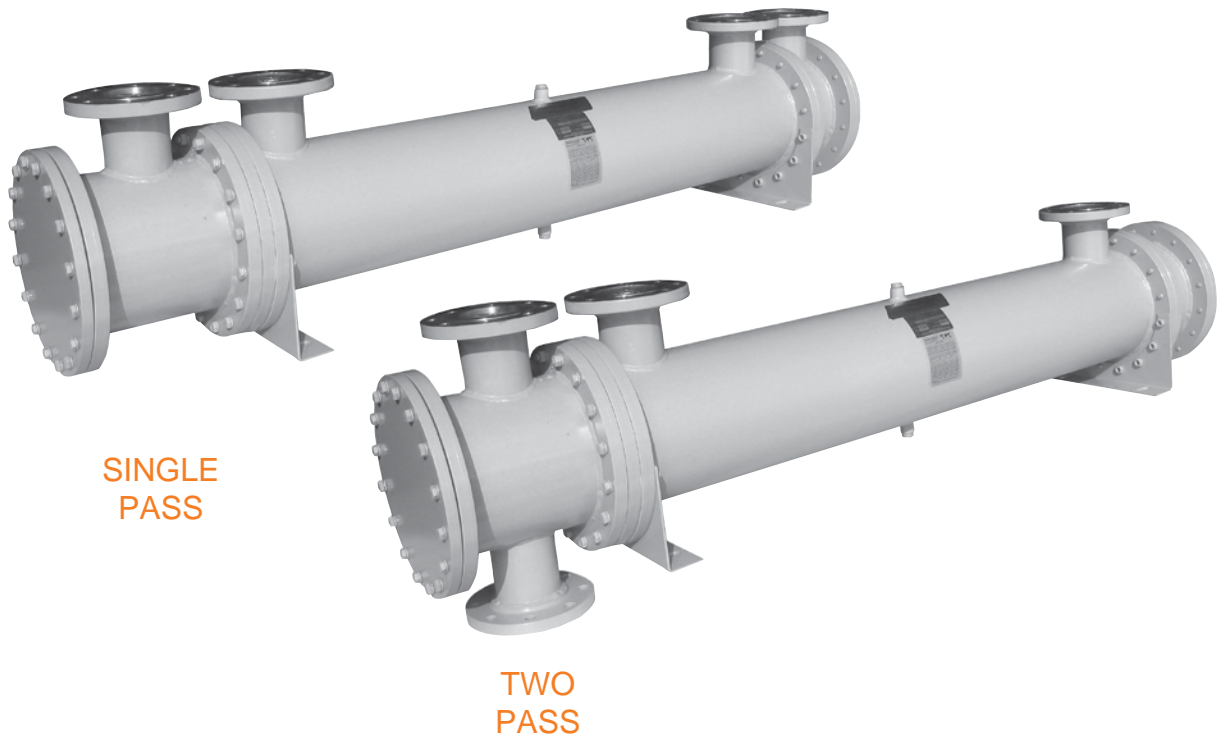

SRCS SERIES



Strait Tube Removable Bundle / Liquid Cooled

HEAT EXCHANGERS

- Removable strait-tube bundle
- Brass stationary and floating tube sheets.
- Brass packing and retaining rings.
- Dual Viton O-ring packing seals.
- Removable channel covers for access to tubes without disturbing existing plumbing.
- Operating pressure, 150 PSI tubes, 225 PSI shell.
- Operating temperature 400°F
- Can be customized to fit your needs.
- Cools: Fluid power systems, rock crushers, presses, shears, lubrication equipment for paper machinery, gear drives, marine transmissions, etc.



SRCS SERIES

Straight tube heat exchangers with removeable tube bundle for fluids with high differential inlet temperatures or in applications where tube bundle requires removal. Normally applied when the differential temperature between the hot fluid entering and the cooling fluid entering is 150°F or greater. Strait tube design allows tubing to freely expand and contract independently of the shell. Welded outer shell construction made of carbon steel. Sizes from 6" to 20" diameters. Standard one and two pass units available. Optional 90/10 copper nickel, stainless steel, and carbon steel tube. Can be modified to meet your requirements.

UCS & URCS SERIES

U-tube heat exchangers with removeable tube bundle for fluids with high differential inlet temperatures or where tube bundle requires removal. Normally applied when the differential temperature between the hot fluid entering and the cooling fluid entering is 150°F or greater. U-tube design allows tubing to freely expand and contract independently of the shell. Welded outer shell construction made of carbon steel. Sizes from 3" to 10" diameters. Standard two and four pass units available. Optional 90/10 copper nickel, stainless steel, and carbon steel tube. Can be modified to meet your requirements.

(See Page 89)

UCN, URCN & UCF, URCF SERIES

U-tube heat exchangers with removeable tube bundle for steam service. Normally applied when the differential temperature between the hot fluid entering and the cooling fluid entering is 150°F or greater. U-tube design allows tubing to freely expand and contract independently of the shell. Welded outer shell construction made of carbon steel. Sizes from 5" to 10" diameters. Standard two and four pass units available. Optional 90/10 copper nickel, stainless steel, and carbon steel tube. Can be modified to meet your requirements.

(See Page 105)

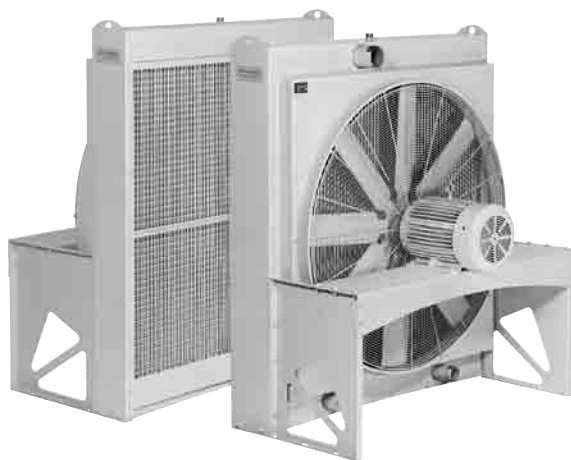

AOCS Series WITH ELECTRIC DRIVE

Severe duty air-cooled oil coolers, super capacity, rolled tube industrial series heat exchangers with direct electric drive cooling fan, OSHA guard, and heavy duty front screen. Rated operating temperature of 300°F at 200 PSIG. Standard flow rates from 10 to 600 GPM. NPT, ANSI flange, or SAE code 61 four bolt flange port connections. Optional built-in bypass relief valve 30 PSI or 65 PSI. Can be modified to meet your requirements. Suitable for most hydraulic oils, lubrications oils, synthetic compressor oils, ethylene glycol, and many other fluids compatible with listed material.

In applications where water is not available for cooling (see page 157)

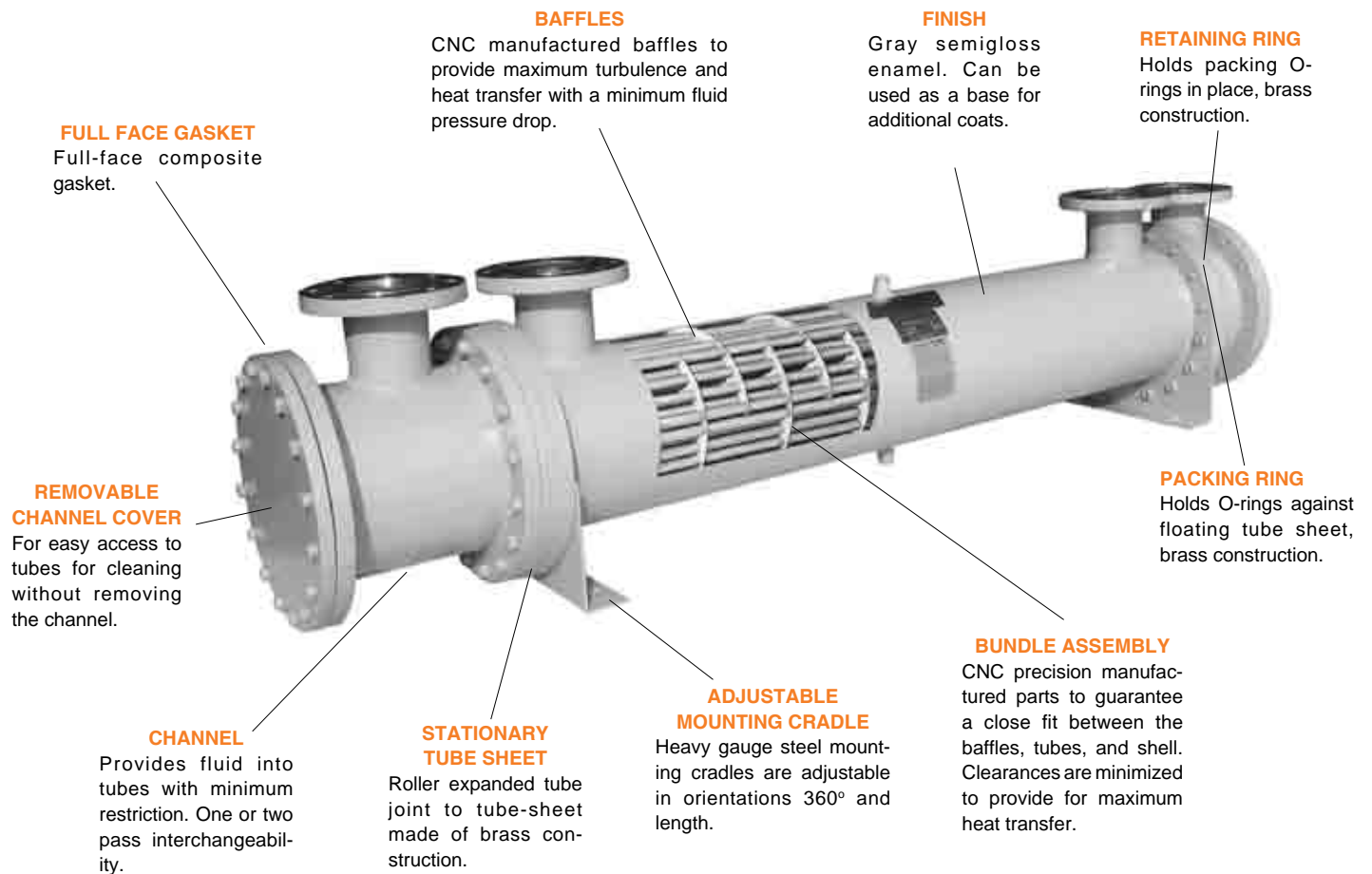

UNIT CODING

Example Model

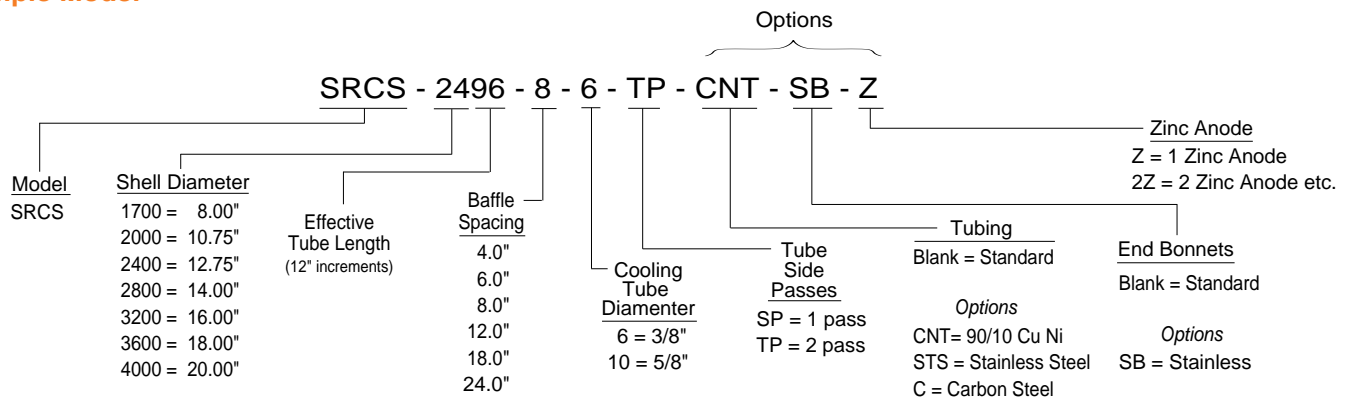

STANDARD CONSTRUCTION MATERIALS & RATINGS

Standard Model	SRCS 1700 - 4000	Options	Standard Unit Ratings
Shell	Steel	Stainless Steel	Operating Pressure Tubes 150 psig Operating Pressure Shell 225 psig Operating Temperature 400 °F
Tubes	Copper	90/10 Cu. Ni. / Stainless Steel	
Baffles	Steel	Brass / Stainless Steel	
Tube Sheets	Brass	Steel / Stainless Steel	
Retaining Ring	Brass	Steel / Stainless Steel	
Packing Ring	Brass	Steel / Stainless Steel	
Gaskets / Packing	Hypalon / Viton	Viton / EPDM / EPR	
Mounting Brackets	Steel	Stainless Steel	
Bonnets / Channels	Cast Iron / Steel	Stainless Steel	

note: AIHTI reserves the right to make reasonable design changes without notice.

SRCS Series selection

STEP 1: Calculate the heat load

The heat load in BTU/HR or (Q) can be derived by using several methods. To simplify things, we will consider general specifications for hydraulic system oils and other fluids that are commonly used with shell & tube heat exchangers.

Terms			
GPM	= Gallons Per Minute	Kw	= Kilowatt (watts x 1000)
CN	= Constant Number for a given fluid	T _{in}	= Hot fluid entering temperature in °F
ΔT	= Temperature differential across the potential	T _{out}	= Hot fluid exiting temperature in °F
PSI	= Pounds per Square Inch (pressure) of the operating side of the system	t _{in}	= Cold fluid temperature entering in °F
MHP	= Horsepower of the electric motor driving the hydraulic pump	t _{out}	= Cold fluid temperature exiting in °F
		Q	= BTU / HR

For example purposes, a hydraulic system has a total input 1200 HP (894Kw) electric motor installed coupled to a pump that produces a flow of 600 GPM @ 3000 PSIG. The temperature differential of the oil entering the pump vs exiting the system is about 6.6°F. Even though return line pressure operates below 200 psi, calculate the system heat load potential (Q) based upon the prime movers (pump) capability, cooling fluid is water @ 80°F use one of the following equations to accomplish this:

To derive the required heat load (Q) to be removed by the heat exchanger, apply ONE of the following. Note: The calculated heat loads may differ slightly from one formula to the next. This is due to assumptions made when estimating heat removal requirements. The factor (ν) represents the percentage of the overall input energy to be rejected by the heat exchanger. The (ν) factor is generally about 30% for most hydraulic systems, however it can range from 20%-70% depending upon the installed system components and heat being generated (ie. servo valves, proportional valves, etc...will increase the percentage required).

FORMULA	EXAMPLE
A) Q = GPM x CN x actual ΔT	A) Q = 600 x 210 x 6.6°F = 831,600 BTU/HR
B) Q = [(PSI x GPM) / 1714] x (ν) x 2545	B) Q = [(3000x600)/1714] x .30 x 2545 = 801,808 BTU/HR
C) Q = MHP x (ν) x 2545	C) Q = 1200 x .30 x 2545 = 916,200 BTU/HR
D) Q = Kw to be removed x 3415	D) Q = 894 x .30 x 3415 = 915,909 BTU/HR
E) Q = HP to be removed x 2545	E) Q = 300 x 2545 = 736,500 BTU/HR

Constant for a given fluid (CN)

- 1) Oil CN = 210
- 2) Water..... CN = 500
- 3) 50% E. Glycol..... CN = 450

STEP 2: Calculate the Mean Temperature Difference

When calculating the MTD you will be required to choose a liquid flow rate to derive the cold side ΔT. If the water flow is unknown you may need to assume a number based on what is available. As a normal rule of thumb, for oil to water cooling a 2:1 oil to water ratio is used. For applications of water to water or 50 % Ethylene Glycol to water, a 1:1 ratio is common.

FORMULA	EXAMPLE (from step 1, item c)
HOT FLUID Oil $\Delta T = \frac{Q}{CN \times GPM}$	$\Delta T = \frac{916,200 \text{ BTU/hr}}{210 \text{ CN} \times 600 \text{ GPM}} = 7.37^\circ\text{F} = \Delta T \text{ Rejected}$
COLD FLUID Water $\Delta t = \frac{\text{BTU / hr}}{CN \times GPM}$	$\Delta t = \frac{916,200 \text{ BTU/hr}}{500 \text{ CN} \times 300 \text{ GPM}} = 3.81^\circ\text{F} = \Delta t \text{ Absorbed}$
T _{in} = Hot Fluid entering temperature in degrees F	T _{in} = 117.3 °F
T _{out} = Hot Fluid exiting temperature in degrees F	T _{out} = 110.0 °F
t _{in} = Cold Fluid entering temperature in degrees F	t _{in} = 80.0 °F
t _{out} = Cold Fluid exiting temperature in degrees F	t _{out} = 86.1 °F
$\frac{T_{out} - t_{in}}{T_{in} - t_{out}} = \frac{S[\text{smaller temperature difference}]}{L[\text{larger temperature difference}]} = \left(\frac{S}{L}\right)$	$\frac{110.0^\circ\text{F} - 80.0^\circ\text{F}}{117.3^\circ\text{F} - 86.1^\circ\text{F}} = \frac{30.0^\circ\text{F}}{31.2^\circ\text{F}} = .962$

STEP 3: Calculate Log Mean Temperature Difference (LMTD)

To calculate the LMTD please use the following method;

L = Larger temperature difference from step 2.

M = S/L number (LOCATED IN TABLE A). .962 = .980

LMTD_i = L x M

$$\text{LMTD}_i = 31.2 \times .980 \text{ (FROM TABLE A)} = 30.6$$

To correct the LMTD_i for a multipass heat exchangers calculate **R** & **K** as follows:

FORMULA	EXAMPLE
$R = \frac{T_{in} - T_{out}}{t_{out} - t_{in}}$	$R = \frac{117.3^\circ\text{F} - 100^\circ\text{F}}{86.1^\circ\text{F} - 90^\circ\text{F}} = \frac{17.3^\circ\text{F}}{6.1^\circ\text{F}} = \{2.82=R\}$
$K = \frac{t_{out} - t_{in}}{T_{in} - t_{in}}$	$K = \frac{86.1^\circ\text{F} - 80^\circ\text{F}}{117.3^\circ\text{F} - 80^\circ\text{F}} = \frac{6.1^\circ\text{F}}{37.3^\circ\text{F}} = \{.163=K\}$

Locate the correction factor CF_B
(FROM TABLE B)
LMTD_c = LMTD_i x CF_B
LMTD_c = 30.6 x .996 = **30.5**

STEP 4: Calculate the area required

$$\text{Required Area sq.ft.} = \frac{Q \text{ (BTU / HR)}}{\text{LMTD}_c \times U \text{ (FROM TABLE C)}} = \frac{916,200}{30.5 \times 100} = \mathbf{300.4 \text{ sq.ft.}}$$

STEP 5: Selection

a) From TABLE E choose the correct series size, baffle spacing, and number of passes that best fits your flow rates for both shell and tube side. Note that the tables suggest minimum and maximum information. Try to stay within the 20-80 percent range of the indicated numbers.

Example

Oil Flow Rate = 600 GPM = Series Required from Table E = **2400 Series**
 Baffle Spacing from Table E = **18 baffle**

Water Flow Rate = 300 GPM = Passes required in 2000 series = **TP**

b) From TABLE D choose the heat exchanger model size based upon the sq.ft. or surface area in the series size that will accommodate your flow rate.

Example

Required Area = 300.4 sq.ft. Closest model required based upon sq.ft. & series = **SRCS-2484-18-6-TP**

If you require a computer generated data sheet for the application, or if the information that you are trying to apply does not match the corresponding information, please contact our engineering services department for further assistance.

TABLE E

Shell Dia. Code	Max. Liquid Flow - Shell Side						Liquid Flow - Tube Side					
	4	6	8	12	18	24	SP		TP		FP	
							Min.	Max.	Min.	Max.	Min.	Max.
1700	140	165	190	210	220	—	52	418	26	164	13	82
2000	150	220	300	440	550	—	82	590	41	290	23	145
2400	155	235	310	470	700	930	125	980	64	486	31	240
2800	170	255	345	510	770	1030	150	1200	75	600	38	300
3200	200	295	395	590	890	1175	200	1600	100	800	50	400
3600	225	335	445	665	1000	1330	258	2068	129	1031	65	514
4000	250	375	495	745	1120	1490	322	2586	160	1290	81	645

TABLE C

U	TUBE FLUID	SHELL FLUID
400	Water	Water
350	Water	50% E. Glycol
100	Water	Oil
300	50% E. Glycol	50% E. Glycol
90	50% E. Glycol	Oil

TABLE A- FACTOR M/LMTD = L x M

S/L	M	S/L	M	S/L	M	S/L	M
.01	.215	.26	.541	.50	.721	.75	.870
.02	.251	.27	.558	.51	.728	.76	.864
.03	.277	.28	.566	.53	.740	.78	.886
.04	.298	.29	.574	.54	.746	.79	.890
.05	.317	.30	.582	.55	.753	.80	.896
.06	.334	.31	.589	.56	.759	.81	.902
.07	.350	.32	.597	.57	.765	.82	.907
.08	.364	.33	.604	.58	.771	.83	.913
.09	.378	.34	.612	.59	.777	.84	.918
.10	.391	.35	.619	.60	.783	.85	.923
.11	.403	.36	.626	.61	.789	.86	.928
.12	.415	.37	.634	.62	.795	.87	.934
.13	.427	.38	.641	.63	.801	.88	.939
.14	.438	.39	.648	.64	.806	.89	.944
.15	.448	.40	.655	.65	.813	.90	.949
.16	.458	.41	.662	.66	.818	.91	.955
.17	.469	.42	.669	.67	.823	.92	.959
.18	.478	.43	.675	.68	.829	.93	.964
.19	.488	.44	.682	.69	.836	.94	.970
.20	.497	.45	.689	.70	.840	.95	.975
.21	.506	.46	.695	.71	.848	.96	.979
.22	.515	.47	.702	.72	.852	.97	.986
.23	.524	.48	.709	.73	.858	.98	.991
.24	.533	.49	.715	.74	.864	.99	.995

TABLE B- LMTD correction factor for Multipass Exchangers

	.05	.1	.15	.2	.25	.3	.35	.4	.45	.5	.6	.7	.8	.9	1.0
.2	1	1	1	1	1	1	1	.999	.993	.984	.972	.942	.908	.845	.71
.4	1	1	1	1	1	1	.994	.983	.971	.959	.922	.855	.70		
.6	1	1	1	1	1	.992	.980	.965	.948	.923	.840				
.8	1	1	1	1	.995	.981	.965	.945	.916	.872					
1.0	1	1	1	1	.988	.970	.949	.918	.867	.770					
2.0	1	1	.977	.973	.940	.845	.740								
3.0	1	1	.997	.933	.835										
4.0	1	.993	.950	.850											
5.0	1	.982	.917												
6.0	1	.968	.885												
8.0	1	.930													
10.0	.996	.880													
12.0	.985	.720													
14.0	.972														
16.0	.958														
18.0	.940														
20.0	.915														

R

K

TABLE D- Surface Area

Model Number	Surface Area in Sq. ft.		Model Number	Surface Area in Sq. ft.		Model Number	Surface Area in Sq. ft.		Model Number	Surface Area in Sq. ft.	
	3/8" O.D. Tubing	5/8" O.D. Tubing		3/8" O.D. Tubing	5/8" O.D. Tubing		3/8" O.D. Tubing	5/8" O.D. Tubing		3/8" O.D. Tubing	5/8" O.D. Tubing
SRCS-1736	55.3	33.3	SRCS-2472	286.3	149.2	SRCS-3248	336.9	179.3	SRCS-36144	1324.0	730.0
SRCS-1748	73.8	44.5	SRCS-2484	334.0	174.1	SRCS-3260	421.1	224.1	SRCS-36156	1434.0	791.0
SRCS-1760	92.2	55.6	SRCS-2496	381.7	199.0	SRCS-3272	505.4	268.9	SRCS-36168	1544.0	852.0
SRCS-1772	110.7	66.7	SRCS-24108	429.4	223.8	SRCS-3284	589.6	313.8	SRCS-36180	1655.0	913.0
SRCS-1784	129.1	77.8	SRCS-24120	477.1	248.7	SRCS-3296	673.8	358.6			
SRCS-1796	147.6	89.0	SRCS-24132	524.8	273.6	SRCS-32108	758.1	403.4	SRCS-4048	545.8	299.7
SRCS-17108	166.1	100.1	SRCS-24144	572.5	298.5	SRCS-32120	842.3	448.3	SRCS-4060	682.3	374.7
						SRCS-32132	926.5	493.1	SRCS-4072	818.7	449.6
SRCS-2036	104.8	53.9	SRCS-2836	186.1	96.2	SRCS-32144	1010.8	537.9	SRCS-4084	955.2	524.5
SRCS-2048	139.8	72.0	SRCS-2848	248.1	128.2	SRCS-32156	1095.0	582.8	SRCS-4096	1091.7	599.5
SRCS-2060	174.7	90.0	SRCS-2860	310.2	160.5	SRCS-32168	1179.2	627.6	SRCS-40108	1228.0	674.4
SRCS-2072	209.7	108.0	SRCS-2872	372.2	192.4				SRCS-40120	1364.6	749.4
SRCS-2084	244.6	126.0	SRCS-2884	434.3	224.4	SRCS-3648	441.4	243.5	SRCS-40132	1501.0	824.3
SRCS-2096	279.6	144.0	SRCS-2896	496.3	256.5	SRCS-3660	551.7	304.3	SRCS-40144	1637.5	899.2
SRCS-20108	314.5	162.0	SRCS-28108	558.4	290.4	SRCS-3672	662.1	356.2	SRCS-40156	1774.0	974.2
SRCS-20120	349.5	180.0	SRCS-28120	620.4	320.7	SRCS-3684	772.4	426.1	SRCS-40168	1910.4	1049.1
			SRCS-28132	682.5	352.7	SRCS-3696	882.8	486.9	SRCS-40180	2046.9	1124.1
SRCS-2436	143.1	74.6	SRCS-28144	744.5	384.8	SRCS-36108	993.1	547.8			
SRCS-2448	190.9	99.5	SRCS-28156	806.6	416.9	SRCS-36120	1103.5	608.7			
SRCS-2460	238.6	124.4	SRCS-28168	868.6	448.9	SRCS-36132	1213.8	669.6			

note: AIHTI reserves the right to make reasonable design changes without notice.

dimensions

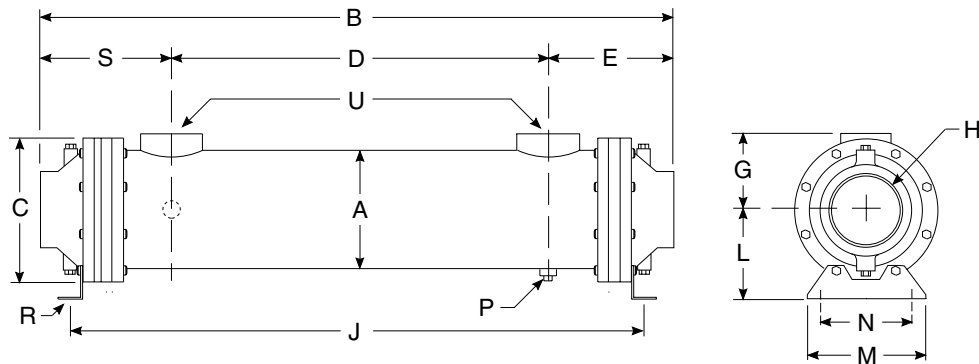

Model	B	S	E	H NPT
SRCS-1736	45.4	8.35	8.04	4.0
SRCS-1748	57.4			
SRCS-1760	69.4			
SRCS-1772	81.4			
SRCS-1784	93.4			
SRCS-1796	105.4			
SRCS-17108	117.4			

SINGLE PASS (SP)

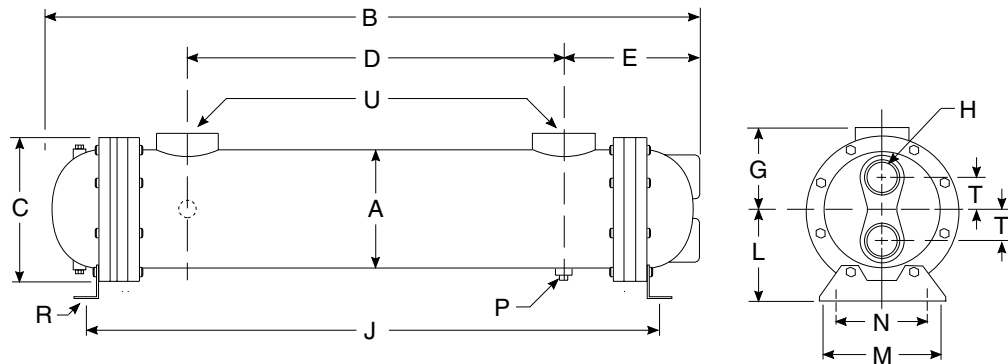

Model	B	E	H NPT	T
SRCS-1736	44.5	7.88	2.5	1.88
SRCS-1748	56.5			
SRCS-1760	68.5			
SRCS-1772	80.5			
SRCS-1784	92.5			
SRCS-1796	104.5			
SRCS-17108	116.5			

TWO PASS (TP)

COMMON DIMENSIONS & WEIGHTS

Model	A	C	D	G	J	L	M	N	P NPT	R	U NPT	Weight	Model
SRCS-1736	8.0	10.12	29.00	5.62	41.4	5.75	8.25	7.0	(2) .38	.44Ø x 1.00" Thru Slot	3.0	205	SRCS-1736
SRCS-1748			41.00		53.4							245	SRCS-1748
SRCS-1760			53.00		65.4							285	SRCS-1760
SRCS-1772			65.00		77.4							325	SRCS-1772
SRCS-1784			77.00		89.4							365	SRCS-1784
SRCS-1796			89.00		101.4							405	SRCS-1796
SRCS-17108			101.00		113.4							445	SRCS-17108

Notes

- Provide sufficient clearance at the stationary tube-sheet end to allow for the complete removal of the tube bundle from the shell. On the floating tube-sheet end provide space to permit removal of the end bonnet.
- Tube bundle removal minimum space required is the model length in inches plus six inches.
Example: SRCS 1760 Effective Tube Length 60" + 6" + channel width = minimum clearance.
- When removing bundle from shell the weight of the tube bundle should not be supported on individual tubes. Weight should be distributed on the tube sheets, support baffle plates, or on blocks contoured to the periphery of the tube bundle.
- SRCS Series tube bundle is removable for replacement bundles (consult factory)
- It is recommended that when a heat exchanger is disassembled, new gaskets and O-rings be used in reassembly.
- Replacement gasket and O-ring seal part numbers are available, for more information (consult factory)

note: AIHTI reserves the right to make reasonable design changes without notice.

SRCS-2000 Series *dimensions*

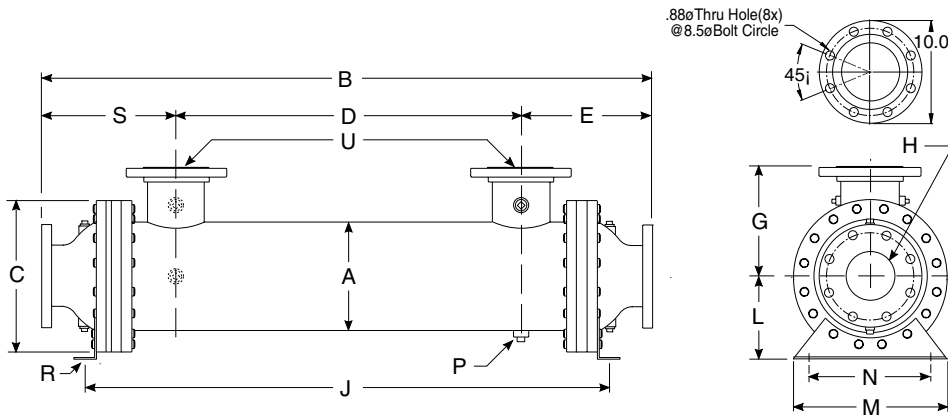

Model	B	S	E	H
SRCS-2036	53.40	14.38	13.90	5.0" ANSI Flange
SRCS-2048	65.40			
SRCS-2060	77.40			
SRCS-2072	89.40			
SRCS-2084	101.40			
SRCS-2096	113.40			
SRCS-20108	125.40			
SRCS-20120	137.40			

SINGLE PASS (SP)

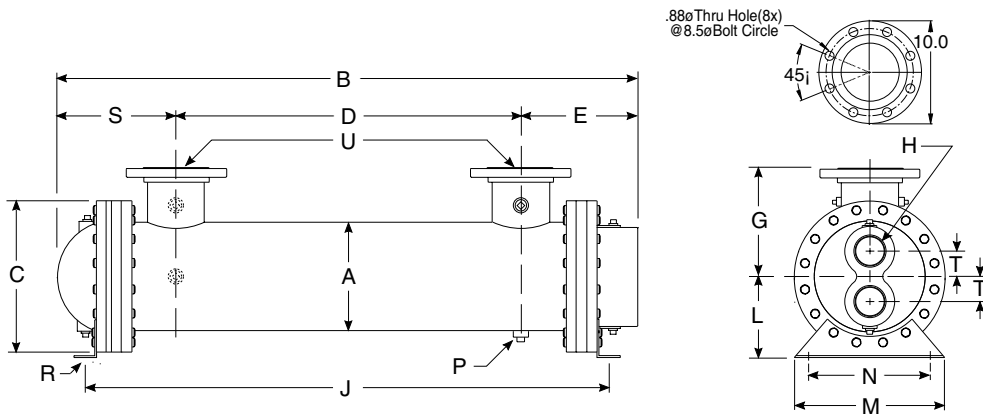

Model	B	E	H NPT	T
SRCS-2036	49.2	11.94	3.00	2.50
SRCS-2048	61.2			
SRCS-2060	73.2			
SRCS-2072	85.2			
SRCS-2084	97.2			
SRCS-2096	109.2			
SRCS-20108	121.2			
SRCS-20120	133.2			

TWO PASS (TP)

COMMON DIMENSIONS & WEIGHTS

Model	A	C	D	G	J	L	M	N	P NPT	R	U	Weight	Model
SRCS-2036	10.75	15.00	26.00	10.75	44.63	8.0	12.0	5.0	(4x) .50	.75"Ø x 1.25" Thru Slot	4.00" ANSI Flange 150# RF	720	SRCS-2036
SRCS-2048			38.00		56.63							780	SRCS-2048
SRCS-2060			50.00		68.63							840	SRCS-2060
SRCS-2072			62.00		80.63							900	SRCS-2072
SRCS-2084			74.00		92.63							960	SRCS-2084
SRCS-2096			86.00		104.63							1020	SRCS-2096
SRCS-20108			98.00		116.63							1080	SRCS-20108
SRCS-20120			110.00		128.63							1150	SRCS-20120

Notes

- Provide sufficient clearance at the stationary tube-sheet end to allow for the complete removal of the tube bundle from the shell. On the floating tube-sheet end provide space to permit removal of the end bonnet.
- Tube bundle removal minimum space required is the model length in inches plus six inches.
Example: SRCS 2060 Effective Tube Length 60" + 6" + channel width = minimum clearance.
- When removing bundle from shell the weight of the tube bundle should not be supported on individual tubes. Weight should be distributed on the tube sheets, support baffle plates, or on blocks contoured to the periphery of the tube bundle.
- SRCS Series tube bundle is removable for replacement bundles (consult factory)
- It is recommended that when a heat exchanger is disassembled, new gaskets and O-rings be used in reassembly.
- Replacement gasket and O-ring seal part numbers are available, for more information (consult factory)

note: AIHTI reserves the right to make reasonable design changes without notice.

Copyright © 2011 American Industrial Heat Transfer, Inc. 355 American Industrial Drive LaCrosse, VA 23950 tel: 434-757-1800 fax: 434-757-1810 email: sales@aihti.com

SRCS-2400 Series dimensions

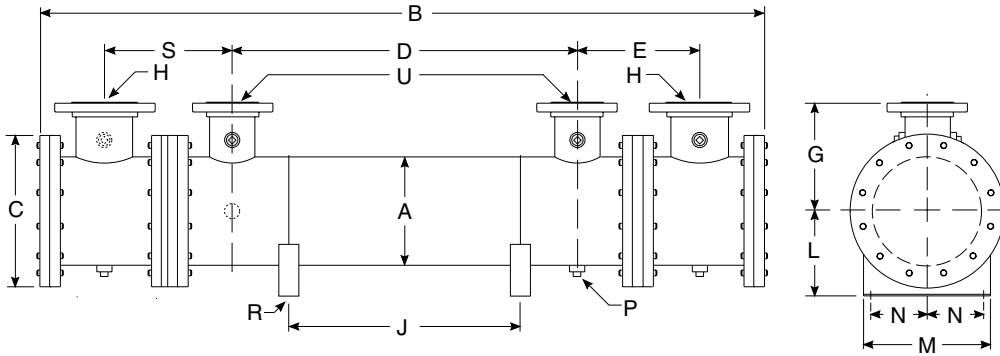

SINGLE PASS (SP)

Model	B	E	H
SRCS-2436	70.63	15.56	8.0 ANSI Flange 150# RF
SRCS-2448	82.63		
SRCS-2460	94.63		
SRCS-2472	106.63		
SRCS-2484	118.63		
SRCS-2496	130.63		
SRCS-24108	142.63		
SRCS-24120	154.63		
SRCS-24132	166.63		
SRCS-24144	178.63		

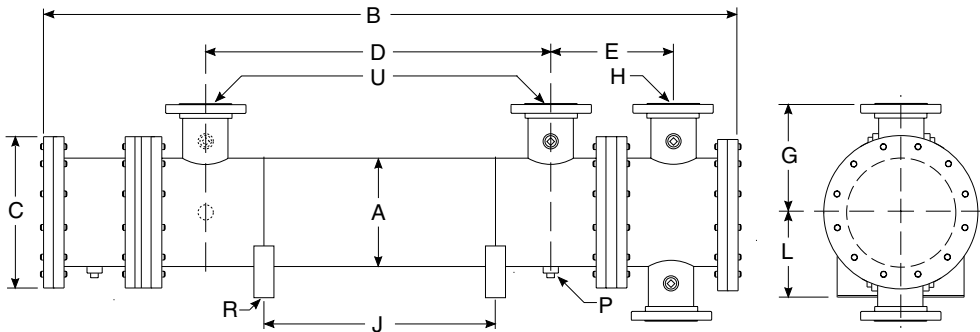

TWO PASS (TP)

Model	B	E	H
SRCS-2436	70.63	15.56	6.0 ANSI Flange 150# RF
SRCS-2448	82.63		
SRCS-2460	94.63		
SRCS-2472	106.63		
SRCS-2484	118.63		
SRCS-2496	130.63		
SRCS-24108	142.63		
SRCS-24120	154.63		
SRCS-24132	166.63		
SRCS-24144	178.63		

COMMON DIMENSIONS & WEIGHTS

Model	A	C	D	G	J	L	M	N	P NPT	R	U	Weight	Model
SRCS-2436	12.75	16.25	24.00	11.38	31.00	12.00	12.75	5.00	.50 (10x)	.75"Ø x 1.00" Thru Slot	6.0 ANSI Flange 150# RF	1040	SRCS-2436
SRCS-2448			36.00		43.00							1130	SRCS-2448
SRCS-2460			48.00		55.00							1221	SRCS-2460
SRCS-2472			60.00		67.00							1312	SRCS-2472
SRCS-2484			72.00		79.00							1402	SRCS-2484
SRCS-2496			84.00		91.00							1493	SRCS-2496
SRCS-24108			96.00		103.00							1584	SRCS-24108
SRCS-24120			108.00		115.00							1675	SRCS-24120
SRCS-24132			120.00		127.00							1766	SRCS-24132
SRCS-24144			132.00		139.00							1857	SRCS-24144

Notes

- Provide sufficient clearance at the stationary tube-sheet end to allow for the complete removal of the tube bundle from the shell. On the floating tube-sheet end provide space to permit removal of the channel cover and channel.
- Tube bundle removal minimum space required is the model length in inches plus six inches.
Example: SRCS 2460 Effective Tube Length 60" + 6" + channel width = minimum clearance.
- When removing bundle from shell the weight of the tube bundle should not be supported on individual tubes. Weight should be distributed on the tube sheets, support baffle plates, or on blocks contoured to the periphery of the tube bundle.
- SRCS Series tube bundle is removable for replacement bundles (consult factory)
- It is recommended that when a heat exchanger is disassembled, new gaskets and O-rings be used in reassembly.
- Replacement gasket and O-ring seal part numbers are available, for more information (consult factory)

note: AIHTI reserves the right to make reasonable design changes without notice.

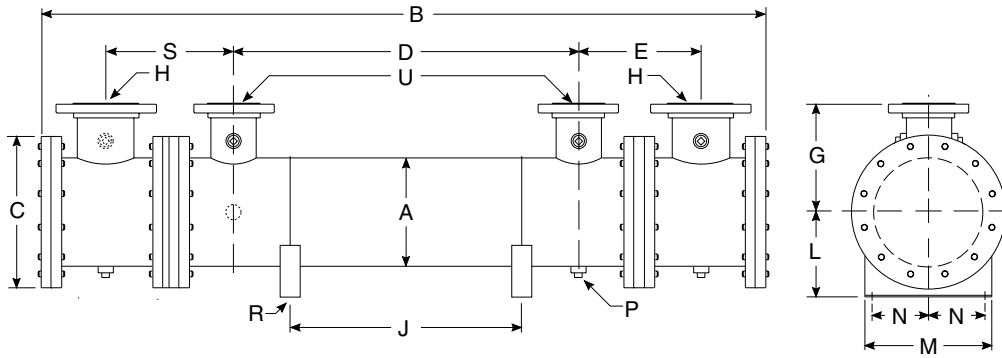

SINGLE PASS (SP)

Model	B	E	H
SRCS-2836	70.63	16.56	8.00" ANSI Flange 150# RF
SRCS-2848	82.63		
SRCS-2860	94.63		
SRCS-2872	106.63		
SRCS-2884	118.63		
SRCS-2896	130.63		
SRCS-28108	142.63		
SRCS-28120	154.63		
SRCS-28132	166.63		
SRCS-28144	178.63		
SRCS-28156	190.63		
SRCS-28168	202.63		

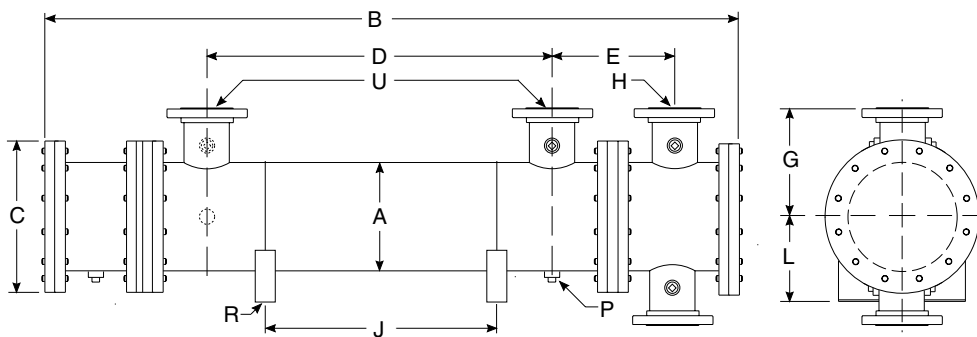

TWO PASS (TP)

Model	B	E	H
SRCS-2836	70.63	16.56	6.00" ANSI Flange 150# RF
SRCS-2848	82.63		
SRCS-2860	94.63		
SRCS-2872	106.63		
SRCS-2884	118.63		
SRCS-2896	130.63		
SRCS-28108	142.63		
SRCS-28120	154.63		
SRCS-28132	166.63		
SRCS-28144	178.63		
SRCS-28156	190.63		
SRCS-28168	202.63		

COMMON DIMENSIONS & WEIGHTS

Model	A	C	D	G	J	L	M	N	P NPT	R	U	Weight	Model
SRCS-2836	14.00	18.00	22.00	12.00	31.00	13.00	14.00	5.00	.50 (10x)	.75"Ø x 1.00" Thru Slot	8.00" ANSI Flange 150# RF	1288	SRCS-2836
SRCS-2848			34.00		43.00							1400	SRCS-2848
SRCS-2860			46.00		55.00							1512	SRCS-2860
SRCS-2872			58.00		67.00							1624	SRCS-2872
SRCS-2884			70.00		79.00							1736	SRCS-2884
SRCS-2896			82.00		91.00							1848	SRCS-2896
SRCS-28108			94.00		103.00							1960	SRCS-28108
SRCS-28120			106.00		115.00							2072	SRCS-28120
SRCS-28132			112.00		127.00							2184	SRCS-28132
SRCS-28144			130.00		139.00							2296	SRCS-28144
SRCS-28156			142.00		151.00							2408	SRCS-28156
SRCS-28168			154.00		163.00							2520	SRCS-28168

Notes

- Provide sufficient clearance at the stationary tube-sheet end to allow for the complete removal of the tube bundle from the shell. On the floating tube-sheet end provide space to permit removal of the channel cover and channel.
- Tube bundle removal minimum space required is the model length in inches plus six inches.
Example: SRCS 2860 Effective Tube Length 60" + 6" + channel width = minimum clearance.
- When removing bundle from shell the weight of the tube bundle should not be supported on individual tubes. Weight should be distributed on the tube sheets, support baffle plates, or on blocks contoured to the periphery of the tube bundle.
- SRCS Series tube bundle is removable for replacement bundles (consult factory)
- It is recommended that when a heat exchanger is disassembled, new gaskets and O-rings be used in reassembly.
- Replacement gasket and O-ring seal part numbers are available, for more information (consult factory)

note: AIHTI reserves the right to make reasonable design changes without notice.

SRCS-3200 Series dimensions

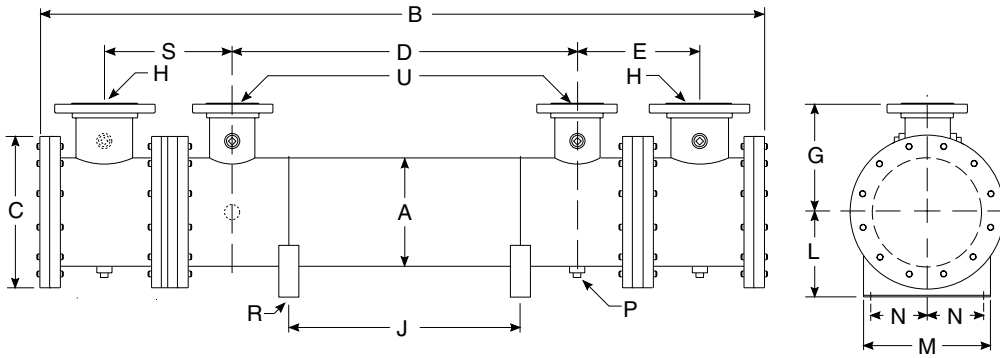

SINGLE PASS (SP)

Model	B	E	H
SRCS-3248	87.63	18.13	10.00" ANSI Flange 150# RF
SRCS-3260	99.63		
SRCS-3272	111.63		
SRCS-3284	123.63		
SRCS-3296	135.63		
SRCS-32108	147.63		
SRCS-32120	159.63		
SRCS-32132	171.63		
SRCS-32144	183.63		
SRCS-32156	195.63		
SRCS-32168	207.63		

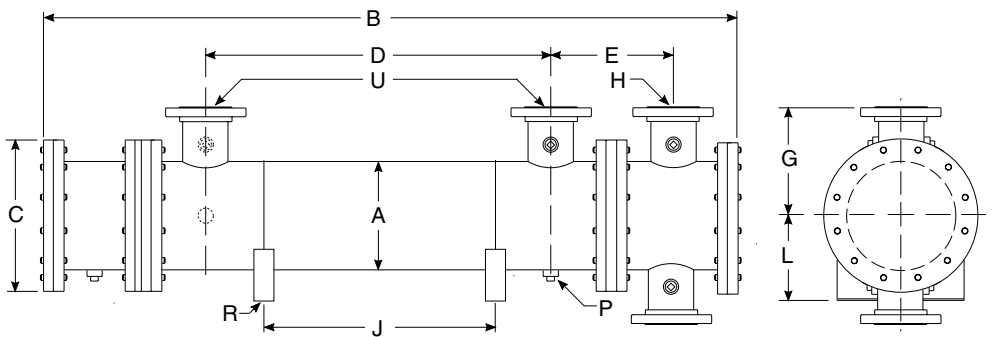

TWO PASS (TP)

Model	B	E	H
SRCS-3248	87.63	18.13	6.00" ANSI Flange 150# RF
SRCS-3260	99.63		
SRCS-3272	111.63		
SRCS-3284	123.63		
SRCS-3296	135.63		
SRCS-32108	147.63		
SRCS-32120	159.63		
SRCS-32132	171.63		
SRCS-32144	183.63		
SRCS-32156	195.63		
SRCS-32168	207.63		

COMMON DIMENSIONS & WEIGHTS

Model	A	C	D	G	J	L	M	N	P NPT	R	U	Weight	Model
SRCS-3248	16.00	20.00	34.00	13.00	43.00	14.00	16.00	6.00	.50 (10x)	.781"Ø x 1.50" Thru Slot	8.00" ANSI Flange 150# RF	2377	SRCS-3248
SRCS-3260			46.00		55.00							1975	SRCS-3260
SRCS-3272			58.00		67.00							2121	SRCS-3272
SRCS-3284			70.00		79.00							2266	SRCS-3284
SRCS-3296			82.00		91.00							2414	SRCS-3296
SRCS-32108			94.00		103.00							2558	SRCS-32108
SRCS-32120			106.00		115.00							2705	SRCS-32120
SRCS-32132			112.00		127.00							2852	SRCS-32132
SRCS-32144			130.00		139.00							2999	SRCS-32144
SRCS-32156			142.00		151.00							3146	SRCS-32156
SRCS-32168			154.00		163.00							3293	SRCS-32168

Notes

- Provide sufficient clearance at the stationary tube-sheet end to allow for the complete removal of the tube bundle from the shell. On the floating tube-sheet end provide space to permit removal of the channel cover and channel.
- Tube bundle removal minimum space required is the model length in inches plus six inches.
Example: SRCS 3260 Effective Tube Length 60" + 6" + channel width = minimum clearance.
- When removing bundle from shell the weight of the tube bundle should not be supported on individual tubes. Weight should be distributed on the tube sheets, support baffle plates, or on blocks contoured to the periphery of the tube bundle.
- SRCS Series tube bundle is removable for replacement bundles (consult factory)
- It is recommended that when a heat exchanger is disassembled, new gaskets and O-rings be used in reassembly.
- Replacement gasket and O-ring seal part numbers are available, for more information (consult factory)

note: AIHTI reserves the right to make reasonable design changes without notice.

SRCS-3600 Series *dimensions*

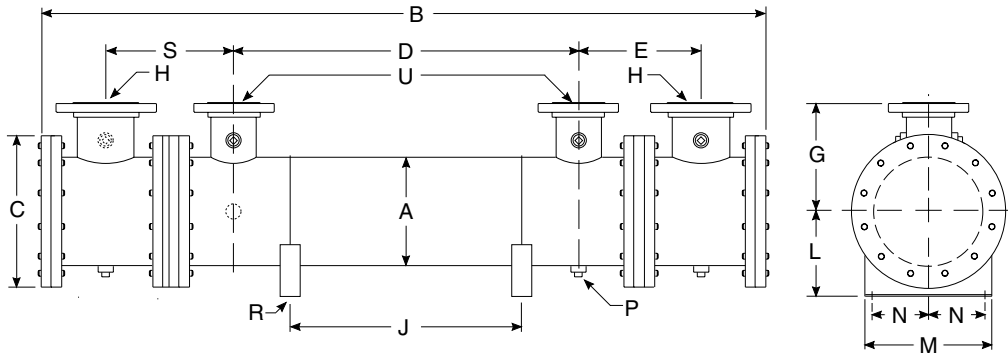

SINGLE PASS (SP)

Model	B	E	H
SRCS-3648	87.63	19.13	10.00" ANSI Flange 150# RF
SRCS-3660	99.63		
SRCS-3672	111.63		
SRCS-3684	123.63		
SRCS-3696	135.63		
SRCS-36108	147.63		
SRCS-36120	159.63		
SRCS-36132	171.63		
SRCS-36144	183.63		
SRCS-36156	195.63		
SRCS-36168	207.63		
SRCS-36180	219.63		

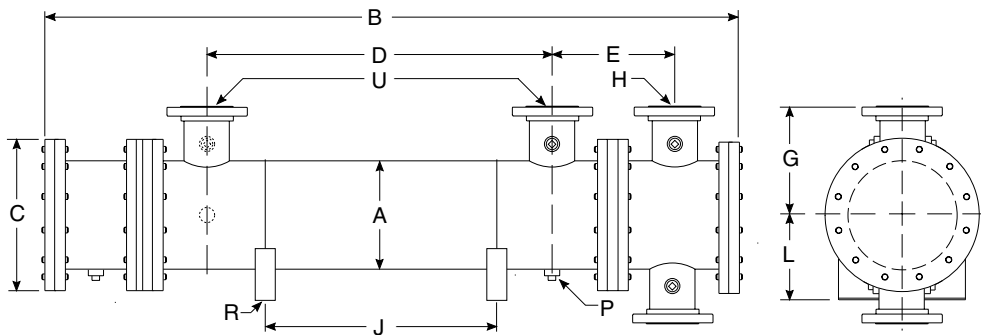

TWO PASS (TP)

Model	B	E	H
SRCS-3648	87.63	19.13	8.00" ANSI Flange 150# RF
SRCS-3660	99.63		
SRCS-3672	111.63		
SRCS-3684	123.63		
SRCS-3696	135.63		
SRCS-36108	147.63		
SRCS-36120	159.63		
SRCS-36132	171.63		
SRCS-36144	183.63		
SRCS-36156	195.63		
SRCS-36168	207.63		
SRCS-36180	219.63		

Model	A	C	D	G	J	L	M	N	P NPT	R	U	Weight	Model
SRCS-3648	18.00	22.00	32.00	14.00	43.00	15.00	16.00	7.00	.50 (6X)	.781"Ø x 1.50" Thru Slot	10.00" ANSI Flange 150# RF	2314	SRCS-3648
SRCS-3660			44.00		55.00							2498	SRCS-3660
SRCS-3672			56.00		67.00							2684	SRCS-3672
SRCS-3684			68.00		79.00							2869	SRCS-3684
SRCS-3696			80.00		91.00							3054	SRCS-3696
SRCS-36108			92.00		103.00							3239	SRCS-36108
SRCS-36120			104.00		115.00							3424	SRCS-36120
SRCS-36132			116.00		127.00							3609	SRCS-36132
SRCS-36144			128.00		139.00							3794	SRCS-36144
SRCS-36156			140.00		151.00							3979	SRCS-36156
SRCS-36168	152.00	163.00	4164	SRCS-36168									
SRCS-36180	164.00	175.00	4349	SRCS-36180									

Notes

- Provide sufficient clearance at the stationary tube-sheet end to allow for the complete removal of the tube bundle from the shell. On the floating tube-sheet end provide space to permit removal of the channel cover and channel.
- Tube bundle removal minimum space required is the model length in inches plus six inches.
Example: SRCS 3660 Effective Tube Length 60" + 6" + channel width = minimum clearance.
- When removing bundle from shell the weight of the tube bundle should not be supported on individual tubes. Weight should be distributed on the tube sheets, support baffle plates, or on blocks contoured to the periphery of the tube bundle.
- SRCS Series tube bundle is removable for replacement bundles (consult factory)
- It is recommended that when a heat exchanger is disassembled, new gaskets and O-rings be used in reassembly.
- Replacement gasket and O-ring seal part numbers are available, for more information (consult factory)

note: AIHTI reserves the right to make reasonable design changes without notice.

SRCS-4000 Series dimensions

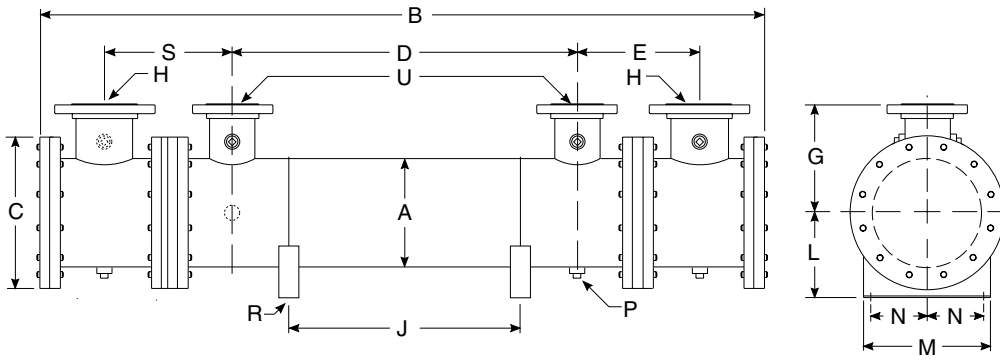

SINGLE PASS (SP)

Model	B	E	H
SRCS-4048	93.68	20.68	12.00" ANSI Flange 150# RF
SRCS-4060	105.68		
SRCS-4072	117.68		
SRCS-4084	129.68		
SRCS-4096	141.68		
SRCS-40108	153.68		
SRCS-40120	165.68		
SRCS-40132	177.68		
SRCS-40144	189.68		
SRCS-40156	201.68		
SRCS-40168	213.68		
SRCS-40180	225.68		

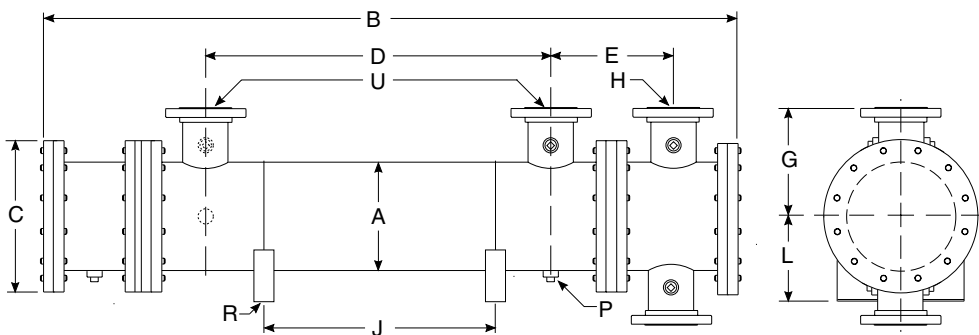

TWO PASS (TP)

Model	B	E	H
SRCS-4048	93.68	20.68	8.00" ANSI Flange 150# RF
SRCS-4060	105.68		
SRCS-4072	117.68		
SRCS-4084	129.68		
SRCS-4096	141.68		
SRCS-40108	153.68		
SRCS-40120	165.68		
SRCS-40132	177.68		
SRCS-40144	189.68		
SRCS-40156	201.68		
SRCS-40168	213.68		
SRCS-40180	225.68		

COMMON DIMENSIONS & WEIGHTS

Model	A	C	D	G	J	L	M	N	P NPT	R	U	Weight	Model
SRCS-4048	20.00	25.00	32.00	16.00	43.00	17.00	20.00	8.00	.50 (6X)	.781"Ø x 1.50" Thru Slot	10.00" ANSI Flange 150# RF	2856	SRCS-4048
SRCS-4060			44.00		55.00							3085	SRCS-4060
SRCS-4072			56.00		67.00							3313	SRCS-4072
SRCS-4084			68.00		79.00							3542	SRCS-4084
SRCS-4096			80.00		91.00							3770	SRCS-4096
SRCS-40108			92.00		103.00							3999	SRCS-40108
SRCS-40120			104.00		115.00							4227	SRCS-40120
SRCS-40132			116.00		127.00							4456	SRCS-40132
SRCS-40144			128.00		139.00							4686	SRCS-40144
SRCS-40156			140.00		151.00							4916	SRCS-40156
SRCS-40168	152.00	163.00	5146	SRCS-40168									
SRCS-40180	164.00	175.00	5376	SRCS-40180									

Notes

- Provide sufficient clearance at the stationary tube-sheet end to allow for the complete removal of the tube bundle from the shell. On the floating tube-sheet end provide space to permit removal of the channel cover and channel.
- Tube bundle removal minimum space required is the model length in inches plus six inches.
Example: SRCS 4060 Effective Tube Length 60" + 6" + channel width = minimum clearance.
- When removing bundle from shell the weight of the tube bundle should not be supported on individual tubes. Weight should be distributed on the tube sheets, support baffle plates, or on blocks contoured to the periphery of the tube bundle.
- SRCS Series tube bundle is removable for replacement bundles (consult factory)
- It is recommended that when a heat exchanger is disassembled, new gaskets and O-rings be used in reassembly.
- Replacement gasket and O-ring seal part numbers are available, for more information (consult factory)

note: AIHTI reserves the right to make reasonable design changes without notice.

PIPING HOOK-UP

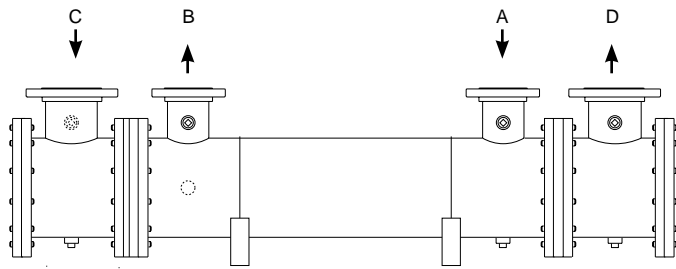

SINGLE PASS

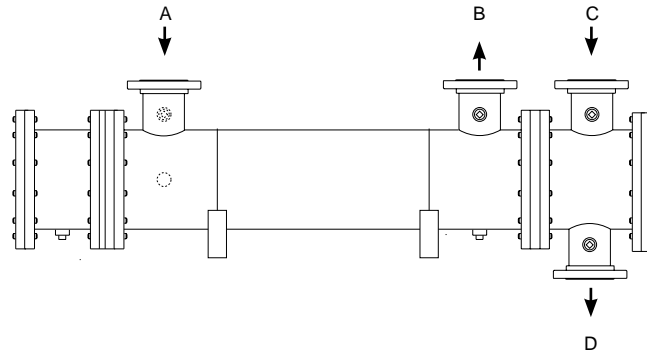

TWO PASS

- A Hot fluid to be cooled
- B Cooled fluid
- C Cooling water in
- D Cooling water out

- SP Single Pass
- TP Two Pass

Receiving / Installation

a) Inspect unit for any shipping damage before uncrating. Indicate all damages to the trucking firms' delivery person, and mark it on the receiving bill before accepting the freight. Make sure that there is no visible damage to the outside surface of the heat exchanger. The published weight information located in this brochure is approximate. True shipment weights are determined at the time of shipping and may vary. Approximate weight information published herein is for engineering approximation purposes and should not be used for exact shipping weight. Since the warranty is based upon the unit date code located on the model identification tags, removal or manipulation of the identification tags will void the manufacturers warranty.

b) When handling the shell & tube heat exchanger, special care should be taken to avoid dropping the unit since mishandling could cause the heat exchanger to crack and leak externally. Mishandling of the unit is not covered under the manufacturers warranty. All units are shipped with partial wood/corrugated cardboard containers for safe handling.

c) Storage: American Industrial heat exchangers are protected against the elements during shipment. If the heat exchanger cannot be installed and put into operation immediately upon receipt, certain precautions are required to prevent deterioration during storage. The responsibility for integrity of the heat exchanger(s) is assumed by the user. American Industrial will not be responsible for damage, corrosion, or other deterioration of the heat exchanger during transit or storage.

Proper storage practices are important when considering the high costs of repair or replacement, and the possible delays for items which require long lead times for manufacture. The following listed practices are provided solely as a convenience to the user, who shall make their own decision on whether to use all or any of them.

- 1) Heat exchangers not to be placed in immediate service, require precautionary measures to prevent corrosion or contamination.
- 2) Heat exchangers made of ferrous materials, may be pressure-tested using compressed air at the factory. Residual oil coating on the inside surfaces of the heat exchanger(s) as a result of flushing does not discount the possibility of internal corrosion. Upon receipt, fill the heat exchanger(s) with the appropriate grade of oil or apply a corrosion preventing inhibitor for storage.
- 3) Corrosion protection compounds for interior surfaces for long term storage or other applications are applied solely at the request of customers. Upon request, American Industrial can provide a customer approved corrosion preventative if available when included in the original purchase order specifications.

- 4) Remove all dirt, water, ice, or snow and wipe dry before moving heat exchanger(s) into storage. Heat exchangers are generally shipped empty, open drain plugs to remove any accumulated condensation moisture, then reseal. Accumulation of moisture usually indicates corrosion has already started and remedial action should be taken.
- 5) Store in a covered, environmentally stable area. The ideal storage environment for heat exchangers is in a dry, low-humidity atmosphere which is sealed to prevent the entry of blowing dust, rain, or snow. Maintain in atmospheric temperatures between 70°F and 105°F (Large temperature swings may cause condensation and moisture to form on steel components, threads, shell, etc...) Use thermometers and humidity indicators and maintain the atmosphere at 40% relative humidity, or lower.

d) Standard Enamel Coating: American Industrial provides its standard products with a normal base coat of oil base air cure enamel paint. The enamel paint is applied as a temporary protective and esthetic coating prior to shipment. While the standard enamel coating is durable, American Industrial does not warranty it as a long-term finish coating. It is strongly suggested that a more durable final coating be applied after installation or prior to long-term storage in a corrosive environment to cover any accidental scratches, enhance esthetics, and further prevent corrosion. It is the responsibility of the customer to provide regular maintenance against chips, scratches, etc... and regular touch up maintenance must be provided for long-term benefits and corrosion prevention.

e) Special Coatings: American Industrial offers as customer options, Air-Dry Epoxy, and Heresite (Air-Dry Phenolic) coatings at additional cost. American Industrial offers special coatings upon request, however American Industrial does not warranty coatings to be a permanent solution for any equipment against corrosion. It is the responsibility of the customer to provide regular maintenance against chips, scratches, etc... and regular touch up maintenance must be provided for long-term benefits and corrosion prevention.

f) American Industrial recommends that the equipment supplied should be installed by qualified personnel who have solid understanding of system design, pressure and temperature ratings, and piping assembly. Verify the service conditions of the system prior to applying any shell & tube heat exchanger. If the system pressure or temperature does not fall within the parameters on model rating tag located on the heat exchanger, contact our factory prior to installation or operation.

note: AIHTI reserves the right to make reasonable design changes without notice.

SRCS 1700 - SRCS 4000 Series *installation & maintenance*

g) Plan the installation to meet the requirements indicated on the piping installation diagram as illustrated above. It is recommended to put the hot fluid to be cooled through the shell side and the cold fluid through the tube side. The indicated port assembly sequence in the installation diagram maximizes the performance, and minimizes the possibility of thermal shock. In instances where the fluids are required to be reversed, *hot fluid in the tubes and cold fluid in the shell* the heat exchanger will work with reduced performance. Installation may be vertical or horizontal or a combination thereof. However, the installation must allow for complete draining of the heat exchanger regardless of two pass or four pass construction. Complete drainage is important to prevent the heat exchanger from freezing, over-heating of a fluid, or mineral deposit buildup.

For removable bundle heat exchangers, provide sufficient clearance at the stationary tube-sheet end to allow for the removal of the tube bundle from the shell. Channel cover can be removed to aid in cleaning the tubes without disassembling the tube bundle. For more information please contact American Industrial.

h) It is recommended to use flexible hose wherever possible to reduce vibration and allow slight movement. However, hoses are not required. Hydraulic carrying lines should be sized to handle the appropriate flow and to meet system pressure drop requirements based upon the systems parameters, and not based upon the units supply and return connection size. We recommend that a low cracking pressure direct acting relief valve be installed at the heat exchanger inlet to protect it from pressure spikes by bypassing oil in the event the system experiences a high flow surge. If preventative filtration is used it should be located ahead of the cooler on both shell and tube side to catch any scale or sludge from the system before it enters the cooler. Failure to install filters ahead of the heat exchanger could lead to possible heat exchanger failure due to high pressure if the system filters plug.

i) Standard shell & tube coolers are built with a rolled tube-sheet construction. However, the differential operating temperature between the entering shell side fluid and the entering tube side fluid should not exceed 150°F. If this condition exists, a severe thermal shock could occur leading to product failure and mixing of the fluids. For applications with a differential temperatures of 150°F or more, we recommend using a series with a floating tube-sheet, u-tube, or expansion joint to reduce the potential for the effects of thermal shock.

j) Water requirements vary from location to location. If the source of cooling water is from other than a municipal water supply, it is recommended that a water strainer be installed ahead of the heat exchanger to prevent dirt and debris from entering and clogging the flow passages. If a water modulating valve is used it is recommended to be installed at the inlet to the cooler to regulate the water flow.

k) For steam service, or other related applications, please consult our engineering department for additional information.

Maintenance

a) Inspect the heat exchanger for loosened bolts, connections, rust spots, corrosion, and for internal or external fluid leakage. Any corroded surfaces should be cleaned and recoated with paint.

b) **Shell side:** In many cases with clean hydraulic system oils it will not be necessary to flush the interior of the shell side of the cooler. In circumstances where the quality of hydraulic fluid is in question, the shell side should be disconnected and flushed on a yearly basis with a clean flushing oil/solvent to remove any sludge that has been deposited. For severe cases where the unit is plugged and cannot be flushed clean with solvent, the heat exchanger should be replaced to maintain the proper cooling performance.

c) **Tube side:** In many cases it will be necessary to clean the tube side of the heat exchanger due to poor fluid quality, debris, calcium deposits, corrosion, mud, sludge, seaweed, etc.... To clean the tube side, flush with clean water or any good quality commercial cleaner that does not attack the particular material of construction. With straight tube heat exchangers you can use a rod to carefully push any debris out of the tubes.

d) **Zinc anodes** are normally used to reduce the risk of failure due to

electrolysis. Zinc anodes are a sacrificial component designed to wear and dissolve through normal use. Normally, zinc anodes are applied to the water supply side of the heat exchanger. Depending upon the amount of corrosive action, one, two, three, or more anodes can be applied to help further reduce the risk of failure. American Industrial Heat Transfer, Inc. offers zinc anodes as an option, to be specified and installed at the request our customers. It is the responsibility of the customer to periodically check and verify the condition of the zinc anode and replace it as needed.

Applications vary due to water chemical makeup and quality, material differences, temperature, flow rate, piping arrangements, and machine grounding. For those reasons, zinc anodes do not follow any scheduled factory predetermined maintenance plan moreover they must be checked routinely by the customer, and a maintenance plan developed based upon the actual wear rate.

If substantial wear occurs or zinc dissolves without replacement, premature failure or permanent damage may occur to the heat exchanger. American Industrial does not warranty customer applications. It is the responsibility of the customer to verify and apply the proper system materials of construction and overall system requirements. Failures resulting from properly applied or misapplied use of zinc anode(s) into non-specified or specified applications will be the sole responsibility of the customer.

e) A routine maintenance schedule should be developed and adjusted to meet your systems requirements based upon water quality, etc... Failure to regularly maintain and clean your heat exchanger can result in a reduction in operational performance and life expectancy.

Note: Since applications can vary substantially, the installation and maintenance information contained in this catalog should be used as a basic guideline. The safe installation, maintenance, and use of any American Industrial Heat Transfer, Inc. heat exchanger are solely the responsibility of the user.

