

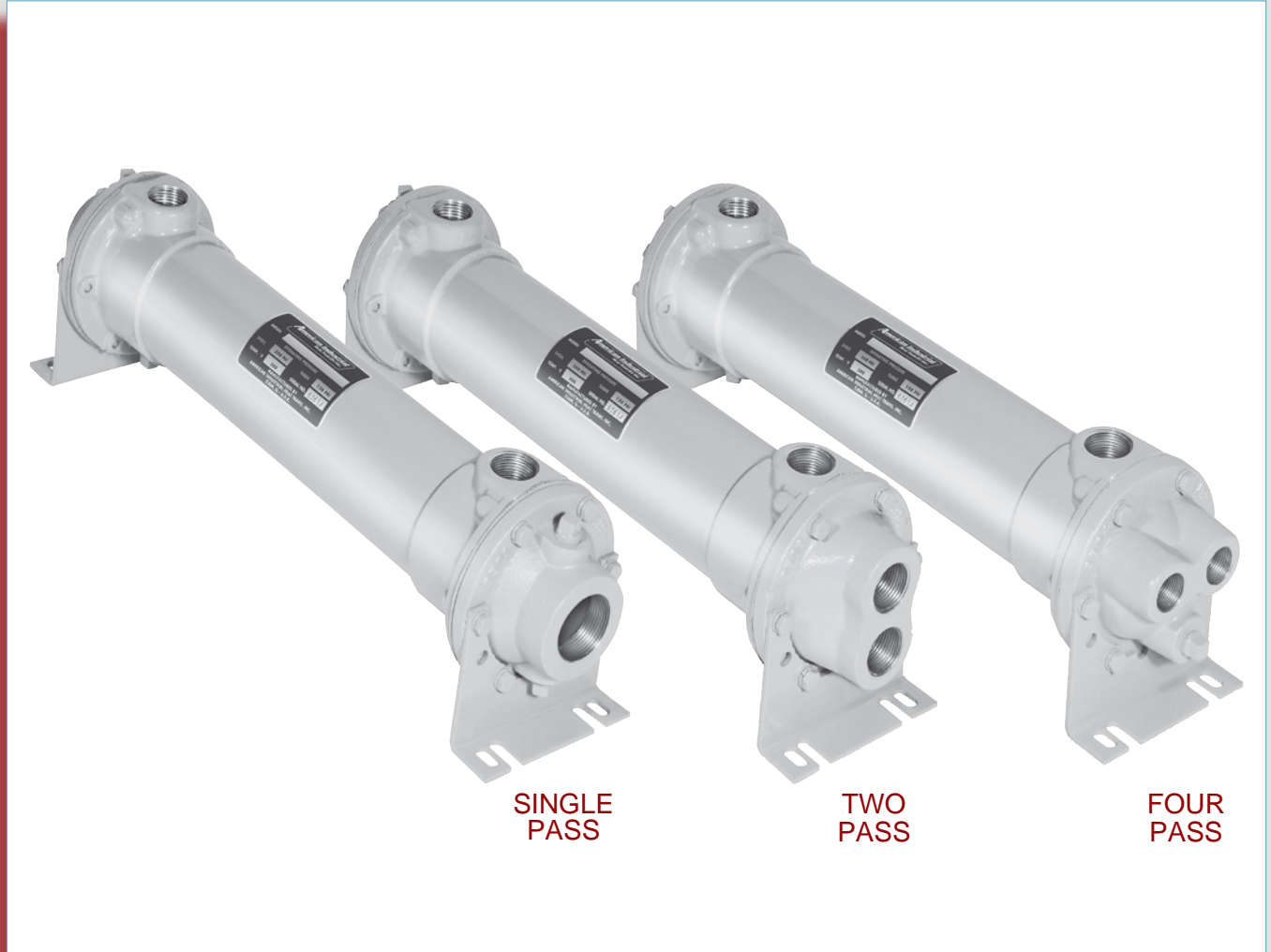

AB - SAE - STS - EAB SERIES



Fixed Tube Bundle / Liquid Cooled

HEAT EXCHANGERS

- Operating pressure for tubes 150 PSI.
- Operating pressure for shell 300 PSI.
- Operating temperature 300 °F.
- Can be customized to fit your needs.
- Cools: Fluid power systems, rock crushers, presses, shears, lubrication equipment for paper machinery, gear drives, marine transmissions, etc.

AB, SAE, STS, & EAB Series overview



AB Series

Fixed tube construction heat exchangers with NPT connections. Made of brass with copper cooling tubes and cast iron end bonnets. Standard sizes from 2" through 8" diameters, and from 1.4 to 308 sq.ft. Standard one, two, and four pass models are available. Options include 90/10 copper nickel and 316 stainless steel cooling tubes, bronze bonnets and zinc anodes. Can be customized to fit your requirements.

Optional 10" diameter units in brass are available upon request.

SAB Series

Similar to AB series with the exception of steel shell material. For use in applications where the shell fluid is non-corrosive with steel. Offered in 5" through 8" shell diameter.



SAE Series

Similar to AB series with the exception of the shell ports. SAE series from 2" through 6" diameter has SAE O-ring straight thread shell port connections. Size 8" diameter has SAE code 61 four bolt flange shell port connections.

SSAE Series

Similar to SAE series with the exception of steel shell material. For use in applications where the shell fluid is non-corrosive with steel. Offered in 5" through 8" shell diameter.



STS Series

Similar in design to AB series with fixed tube construction and NPT connections made of all 316 stainless steel. Standard sizes from 2" through 8" diameters, and from 1.4 to 308 sq.ft. Standard one, two and four pass models are available. Larger diameters available upon request. Can be customized to fit your requirements.



EAB Series

Expansion bellow minimizes the effects of differential expansion and contraction between the shell and cooling tubing, prolonging the overall life of the heat exchanger by reducing fatigue. Fixed tube construction heat exchangers with NPT connections. Made of brass with 90/10 copper nickel cooling tubes, stainless steel expansion bellows, and cast iron end bonnets. Standard sizes from 3.5" through 8" diameters, and from 3.6 to 308 sq.ft. Standard one, two and four pass models are available.

AB, SAE, STS, & EAB Series construction

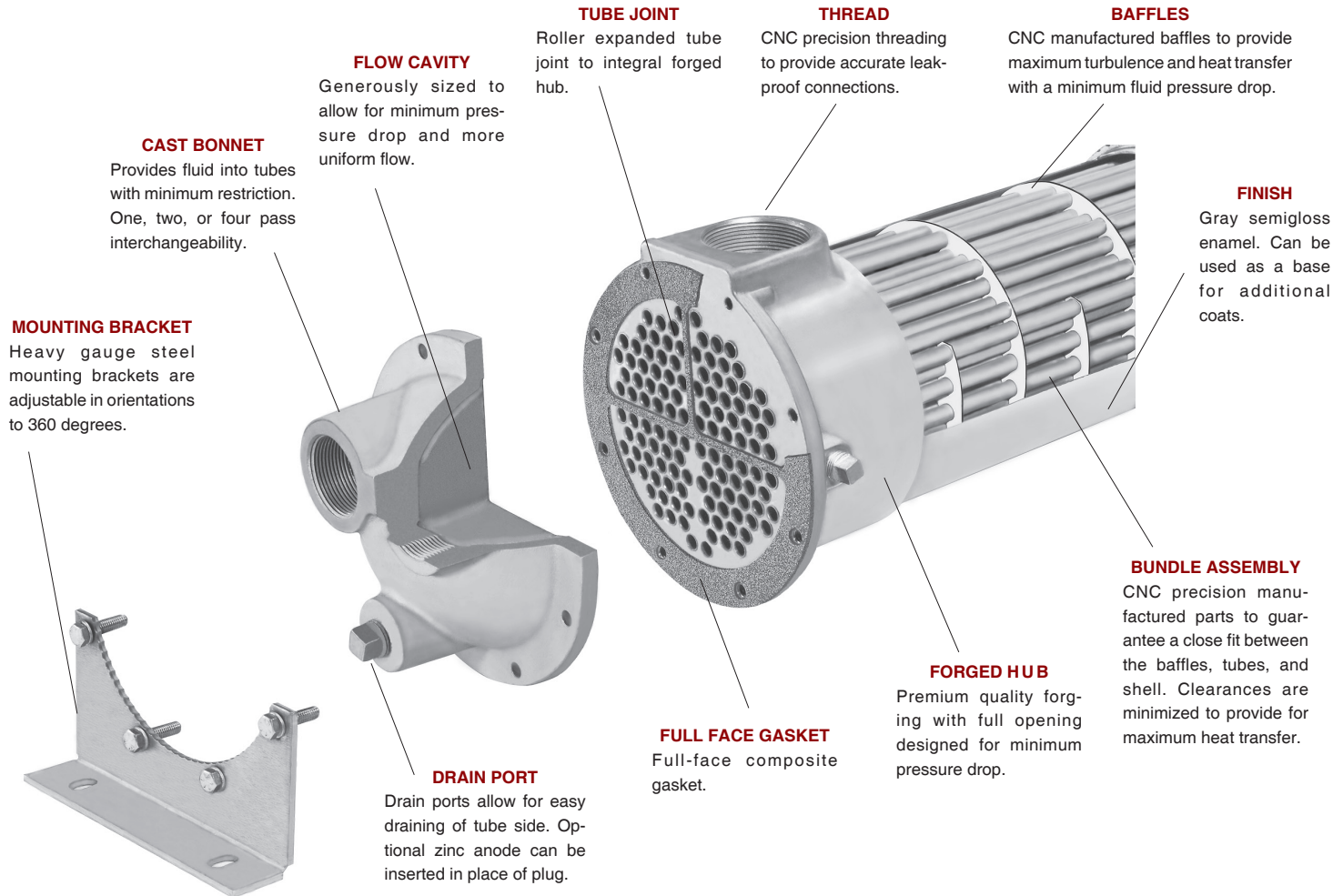

UNIT CODING

Example Model

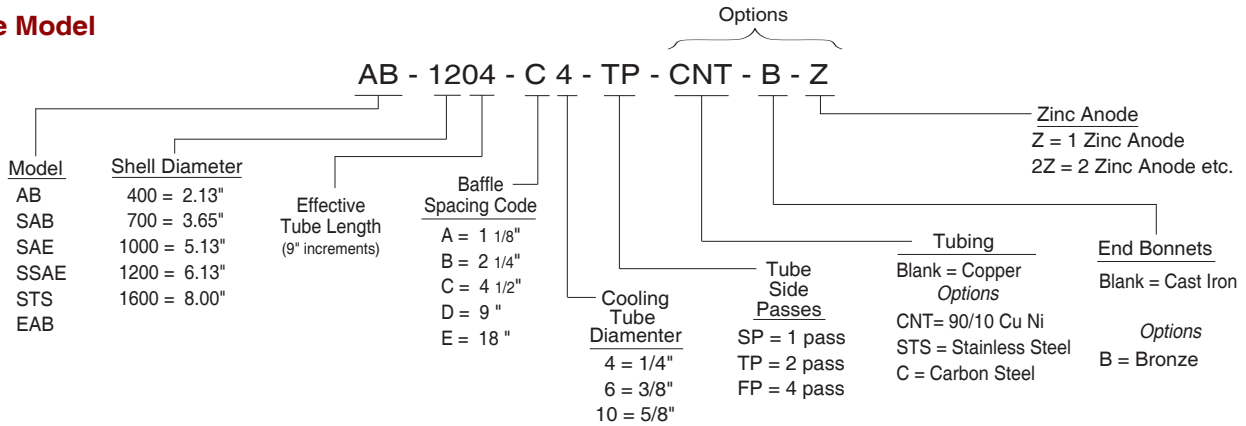

STANDARD CONSTRUCTION MATERIALS & RATINGS

Standard Model	AB Series	SAB & SSAE Series*	SAE Series	STS Series	EAB Series	Standard Unit Ratings
Shell	Brass	Steel	Brass	316 Stainless Steel	Steel	Operating Pressure Tubes.....150 psig
Tubes	Copper	Copper	Copper	316 Stainless Steel	90/10 Copper Nickel	
Baffle	Aluminum	Aluminum	Aluminum	316 Stainless Steel	Aluminum	
Integral End Hub	Forged Brass	Forged Brass	Forged Brass	316 Stainless Steel	Forged Brass	Operating Pressure Shell.....300 psig
End Bonnets	Cast Iron	Cast Iron	Cast Iron	316 Stainless Steel	Cast Iron	
Mounting Brackets	Steel	Steel	Steel	Steel	Steel	Operating Temperature 300 °F
Gasket	Hypalon Composite	Hypalon Composite	Hypalon Composite	Hypalon Composite	High Temp Gasket	
Expansion Bellows	-	-	-	-	Stainless Steel	

*Offered in 5" through 8" shell diameter.

note: AIHTI reserves the right to make reasonable design changes without notice.

Copyright © 2011 American Industrial Heat Transfer, Inc. 355 American Industrial Drive LaCrosse, VA 23950 tel: 434-757-1800 fax: 434-757-1810 email: sales@aihti.com

AB, SAE, STS, & EAB Series selection

STEP 1: Calculate the heat load

The heat load in BTU/HR or (Q) can be derived by using several methods. To simplify things, we will consider general specifications for hydraulic system oils and other fluids that are commonly used with shell & tube heat exchangers.

Terms			
GPM	= Gallons Per Minute	Kw	= Kilowatt (watts x 1000)
CN	= Constant Number for a given fluid	T _{in}	= Hot fluid entering temperature in °F
ΔT	= Temperature differential across the potential	T _{out}	= Hot fluid exiting temperature in °F
PSI	= Pounds per Square Inch (pressure) of the operating side of the system	t _{in}	= Cold fluid temperature entering in °F
MHP	= Horsepower of the electric motor driving the hydraulic pump	t _{out}	= Cold fluid temperature exiting in °F
		Q	= BTU / HR

For example purposes, a hydraulic system has a 125 HP (93Kw) electric motor installed coupled to a pump that produces a flow of 80 GPM @ 2500 PSIG. The temperature differential of the oil entering the pump vs exiting the system is about 5.3°F. Even though our return line pressure operates below 100 psi, we must calculate the system heat load potential (Q) based upon the prime movers (pump) capability. We can use one of the following equations to accomplish this:

To derive the required heat load (Q) to be removed by the heat exchanger, apply ONE of the following. Note: The calculated heat loads may differ slightly from one formula to the next. This is due to assumptions made when estimating heat removal requirements. The factor (ν) represents the percentage of the overall input energy to be rejected by the heat exchanger. The (ν) factor is generally about 30% for most hydraulic systems, however it can range from 20%-70% depending upon the installed system components and heat being generated (ie. servo valves, proportional valves, etc...will increase the percentage required).

FORMULA	EXAMPLE
A) Q = GPM x CN x actual ΔT	A) Q = 80 x 210 x 5.3°F = 89,040 BTU/hr
B) Q = [(PSI x GPM) / 1714] x (ν) x 2545	B) Q = [(2500x80)/1714] x .30 x 2545 = 89,090 BTU/hr
C) Q = MHP x (ν) x 2545	C) Q = 125 x .30 x 2545 = 95,347 BTU/hr
D) Q = Kw to be removed x 3415	D) Q = 28 x 3415 = 95,620 BTU/hr
E) Q = HP to be removed x 2545	E) Q = 37.5 x 2545 = 95,437 BTU/hr

Constant for a given fluid (CN)

- 1) Oil CN = 210
- 2) Water..... CN = 500
- 3) 50% E. Glycol..... CN = 450

STEP 2: Calculate the Mean Temperature Difference

When calculating the MTD you will be required to choose a liquid flow rate to derive the cold side ΔT. If your water flow is unknown you may need to assume a number based on what is available. As a normal rule of thumb, for oil to water cooling a 2:1 oil to water ratio is used. For applications of water to water or 50 % Ethylene Glycol to water, a 1:1 ratio is common.

FORMULA	EXAMPLE
HOT FLUID ΔT = $\frac{Q}{CN \times GPM}$ Oil	ΔT = $\frac{89,090 \text{ BTU/hr (from step 1, example B)}}{210 \text{ CN} \times 80 \text{ GPM}} = 5.3^\circ\text{F} = \Delta T \text{ Rejected}$
COLD FLUID Δt = $\frac{BTU / hr}{CN \times GPM}$ Water	Δt = $\frac{89,090 \text{ BTU/hr}}{500 \text{ CN} \times 40 \text{ GPM (for a 2:1 ratio)}} = 4.5^\circ\text{F} = \Delta t \text{ Absorbed}$
T _{in} = Hot Fluid entering temperature in degrees F	T _{in} = 125.3 °F
T _{out} = Hot Fluid exiting temperature in degrees F	T _{out} = 120.0 °F
t _{in} = Cold Fluid entering temperature in degrees F	t _{in} = 70.0 °F
t _{out} = Cold Fluid exiting temperature in degrees F	t _{out} = 74.5 °F
$\frac{T_{out} - t_{in}}{T_{in} - t_{out}} = \frac{S[\text{smaller temperature difference}]}{L[\text{larger temperature difference}]} = \left(\frac{S}{L} \right)$	$\frac{120.0^\circ\text{F} - 70.0^\circ\text{F} = 50.0^\circ\text{F}}{125.3^\circ\text{F} - 74.5^\circ\text{F} = 50.8^\circ\text{F}} = \frac{50.0^\circ\text{F}}{50.8^\circ\text{F}} = .984$

STEP 3: Calculate Log Mean Temperature Difference (LMTD)

To calculate the LMTD please use the following method;

L = Larger temperature difference from step 2.

M = S/L number (LOCATED IN TABLE A).

LMTD_i = L x M

$$LMTD_i = 50.8 \times .992 \text{ (FROM TABLE A)} = 50.39$$

To correct the LMTD_i for a multipass heat exchangers calculate R & K as follows:

FORMULA	EXAMPLE
$R = \frac{T_{in} - T_{out}}{t_{out} - t_{in}}$	$R = \frac{125.3^\circ\text{F} - 120^\circ\text{F}}{74.5^\circ\text{F} - 70^\circ\text{F}} = \frac{5.3^\circ\text{F}}{4.5^\circ\text{F}} = \{1.17=R\}$
$K = \frac{t_{out} - t_{in}}{T_{in} - t_{in}}$	$K = \frac{74.5^\circ\text{F} - 70^\circ\text{F}}{124.5^\circ\text{F} - 70^\circ\text{F}} = \frac{4.5^\circ\text{F}}{55.4^\circ\text{F}} = \{0.081=K\}$

Locate the correction factor CF_B
(FROM TABLE B)
LMTD_c = LMTD_i x CF_B
LMTD_c = 50.39 x 1 = **50.39**

AB, SAE, STS, & EAB Series selection

STEP 4: Calculate the area required

$$\text{Required Area sq.ft.} = \frac{Q \text{ (BTU / HR)}}{\text{LMTD}_c \times U \text{ (FROM TABLE C)}} = \frac{89,090}{50.39 \times 100} = 17.68 \text{ sq.ft.}$$

STEP 5: Selection

a) From TABLE E choose the correct series size, baffle spacing, and number of passes that best fits your flow rates for both shell and tube side. Note that the tables suggest minimum and maximum information. Try to stay within the 20-80 percent range of the indicated numbers.

Example

Oil Flow Rate = 80 GPM = Series Required from Table E = **1200 Series**
 Baffle Spacing from Table E = **C baffle**
 Water Flow Rate = 40 GPM = Passes required in 1200 series = **4 (FP)**

b) From TABLE D choose the heat exchanger model size based upon the sq.ft. or surface area in the series size that will accommodate your flow rate.

Example

Required Area = 17.68sq.ft. Closest model required based upon sq.ft. & series= **AB-1202-C6-FP**

If you require a computer generated data sheet for the application, or if the information that you are trying to apply does not match the corresponding information, please contact our engineering services department for further assistance.

TABLE A- FACTOR M/LMTD = L x M

S/L	M	S/L	M	S/L	M	S/L	M
.01	.215	.26	.541	.50	.721	.75	.870
.02	.251	.27	.558	.51	.728	.76	.864
.03	.277	.28	.566	.53	.740	.78	.886
.04	.298	.29	.574	.54	.746	.79	.890
.05	.317	.30	.582	.55	.753	.80	.896
.06	.334	.31	.589	.56	.759	.81	.902
.07	.350	.32	.597	.57	.765	.82	.907
.08	.364	.33	.604	.58	.771	.83	.913
.09	.378	.34	.612	.59	.777	.84	.918
.10	.391	.35	.619	.60	.783	.85	.923
.11	.403	.36	.626	.61	.789	.86	.928
.12	.415	.37	.634	.62	.795	.87	.934
.13	.427	.38	.641	.63	.801	.88	.939
.14	.438	.39	.648	.64	.806	.89	.944
.15	.448	.40	.655	.65	.813	.90	.949
.16	.458	.41	.662	.66	.818	.91	.955
.17	.469	.42	.669	.67	.823	.92	.959
.18	.478	.43	.675	.68	.829	.93	.964
.19	.488	.44	.682	.69	.836	.94	.970
.20	.497	.45	.689	.70	.840	.95	.975
.21	.506	.46	.695	.71	.848	.96	.979
.22	.515	.47	.702	.72	.852	.97	.986
.23	.524	.48	.709	.73	.858	.98	.991
.24	.533	.49	.715	.74	.864	.99	.995

TABLE D- Surface Area

Model Number	Surface Area in Sq.ft.			Model Number	Surface Area in Sq.ft.		
	1/4" O.D Tubing	3/8" O.D Tubing	5/8 O.D Tubing		1/4" O.D Tubing	3/8" O.D Tubing	5/8 O.D Tubing
AB-401	1.4	-	-	AB-1602	44.4	30.3	17.6
AB-402	3.0	-	-	AB-1603	66.3	45.3	26.5
AB-403	4.6	-	-	AB-1604	88.3	60.3	35.3
				AB-1605	110.3	75.6	44.1
AB-701	3.6	2.6	-	AB-1606	132.3	90.4	53.0
AB-702	7.3	5.2	-	AB-1607	154.3	105.4	61.8
AB-703	11.1	7.9	-	AB-1608	176.3	120.4	70.6
AB-704	14.9	10.6	-	AB-1609	197.9	135.2	79.5
AB-705	18.7	13.3	-	AB-1610	219.9	150.2	88.3
				AB-1611	241.9	165.2	97.1
AB-1002	17.7	11.2	5.9	AB-1612	263.9	180.2	105.9
AB-1003	26.5	16.8	8.8	AB-1613	285.9	195.2	114.7
AB-1004	35.4	22.4	11.8				
AB-1005	44.3	28.0	14.7	AB-2004	155.1	110.7	60.8
AB-1006	53.2	33.6	17.6	AB-2005	193.8	138.4	76.1
				AB-2006	232.6	166.1	91.3
AB-1202	25.5	17.9	8.8	AB-2007	271.4	193.8	106.5
AB-1203	38.0	26.7	13.2	AB-2008	310.2	221.4	121.7
AB-1204	50.3	35.4	17.6	AB-2009	349.0	249.1	137.0
AB-1205	63.0	44.2	22.1	AB-2010	387.7	276.8	152.2
AB-1206	75.6	53.2	26.5	AB-2011	426.5	304.5	167.4
AB-1207	88.2	62.0	30.9	AB-2012	465.3	332.2	182.7
AB-1208	100.6	70.7	35.3	AB-2013	504.1	359.9	197.9
AB-1209	113.0	79.4	39.6	AB-2014	542.9	387.6	213.2
AB-1210	125.4	88.1	44.1	AB-2015	581.7	415.3	228.4

LMTD correction factor for Multipass Exchangers

	.05	.1	.15	.2	.25	.3	.35	.4	.45	.5	.6	.7	.8	.9	1.0
.2	1	1	1	1	1	1	1	.999	.993	.984	.972	.942	.908	.845	.71
.4	1	1	1	1	1	1	.994	.983	.971	.959	.922	.855	.70		
.6	1	1	1	1	1	.992	.980	.965	.948	.923	.840				
.8	1	1	1	1	.995	.981	.965	.945	.916	.872					
1.0	1	1	1	1	.988	.970	.949	.918	.867	.770					
2.0	1	1	.977	.973	.940	.845	.740								
3.0	1	1	.997	.933	.835										
4.0	1	.993	.950	.850											
5.0	1	.982	.917												
6.0	1	.968	.885												
8.0	1	.930													
10.0	.996	.880													
12.0	.985	.720													
14.0	.972														
16.0	.958														
18.0	.940														
20.0	.915														

TABLE E- Flow Rate for Shell & Tube

Shell dia . Code	Max. Liquid Flow - Shell Side					Liquid Flow - Tube Side					
	Baffle Spacing					SP		TP		FP	
	A	B	C	D	E	Min.	Max.	Min.	Max.	Min.	Max.
400	10	15	20	-	-	3.5	21	-	-	-	-
700	17	29	30	35	-	9	61	4.5	30	2.2	15
1000	24	48	68	70	-	20	120	10	70	5.0	37
1200	29	56	105	115	120	30	250	15	112	7.5	56
1600	38	70	150	200	220	57	460	29	180	14	90
2000	-	-	190	370	550	90	650	45	320	25	160

TABLE C

U	TUBE FLUID	SHELL FLUID
400	Water	Water
350	Water	50% E. Glycol
100	Water	Oil
300	50% E. Glycol	50% E. Glycol
90	50% E. Glycol	Oil

K

note: AIHTI reserves the right to make reasonable design changes without notice.

AB, SAE, STS, & EAB Series performance

Instructions

The selection chart provided contains an array of popular sizes for quick sizing. It does not provide curves for all models available. Refer to page 4 & 5 for detailed calculation information.

Computer selection data sheets for standard or special models are available through the engineering department of American Industrial. To use the followings graphs correctly, refer to the instruction notes "1-5".

- 1) HP Curves are based upon a 40°F approach temperature; for example: oil leaving a cooler at 125°F, using 85°F cooling water (125°F - 85°F = 40°F).
- 2) The oil to water ratio of 1:1 or 2:1 means that for every 1 gallon of oil circulated, a minimum of 1 or 1/2 gallon (respectively) of 85°F water must be circulated to match the curve results.

3) OIL PRESSURE DROP CODING: ♣ = 5 psi; ☆ = 10 psi; ○ = 20 psi; △ = 50psi. Curves that have no pressure drop code symbols indicate that the oil pressure drop is less than 5 psi for the flow rate shown.

4) Pressure Drop is based upon oil with an average viscosity of 100 SSU. If the average oil viscosity is other than 100 SSU, then multiply the indicated Pressure Drop by the corresponding value from corrections table A.

5) Corrections for approach temperature and oil viscosity are as follows:

$$H.P.(\text{In Cooler}) = H.P.(\text{Heat Load}) \times \left(\frac{40}{\text{Actual Approach}} \right) \times B.$$

HEAT ENERGY DISSIPATION RATES (Basic Stock Model)

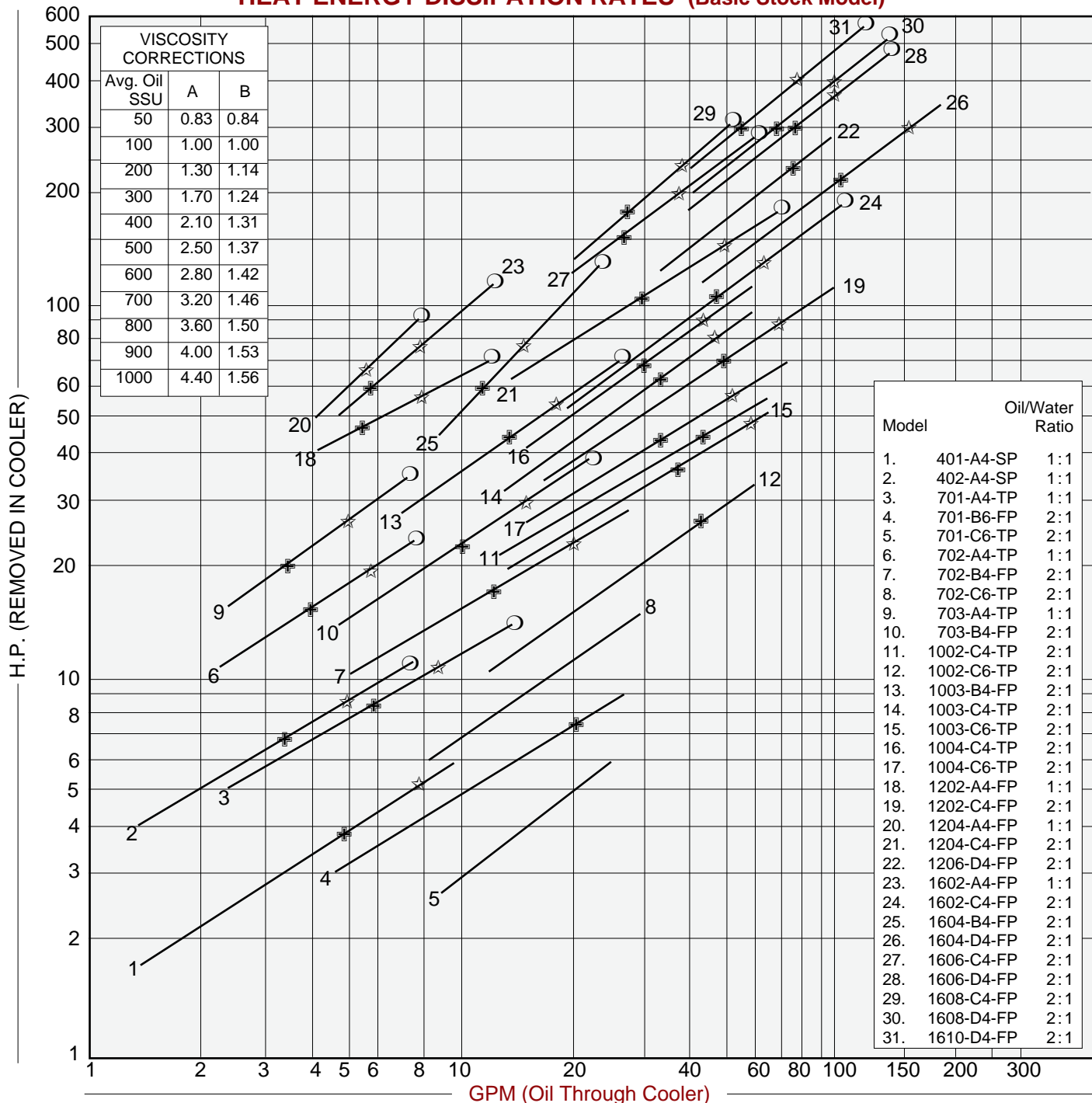

note: AIHTI reserves the right to make reasonable design changes without notice.

AB Series dimensions

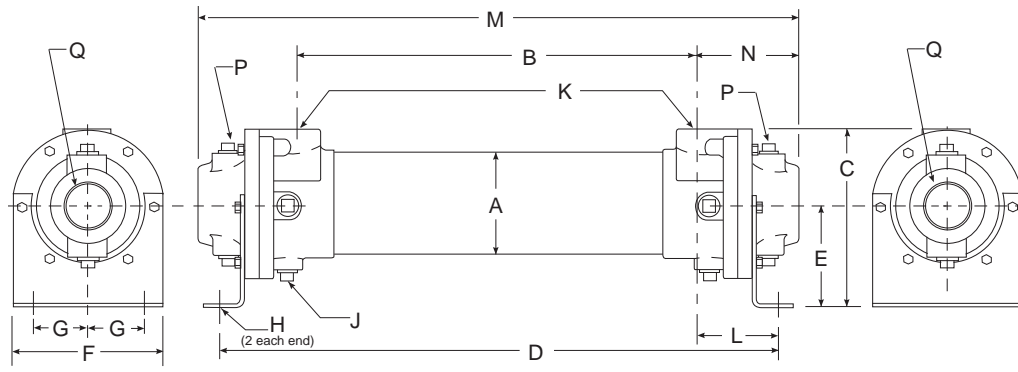

SINGLE PASS (SP)

Model	M	N	P NPT	Q NPT
AB-401	11.24			
AB-402	20.24	1.81	-	1.00
AB-701	13.47			
AB-702	22.47		(4)	
AB-703	31.47	3.24	.38	1.50
AB-704	40.47			
AB-1002	23.60			
AB-1003	32.60	4.05	(4)	2.00
AB-1004	41.60		.38	
AB-1202	24.38			
AB-1203	33.25			
AB-1204	42.12			
AB-1205	51.12			
AB-1206	60.25	4.88	(4)	3.00
AB-1207	69.25		.50	
AB-1208	78.12			
AB-1209	87.12			
AB-1210	96.12			
AB-1602	26.62			
AB-1603	35.62			
AB-1604	44.62			
AB-1605	53.62			
AB-1606	62.62	6.52	(4)	4.00
AB-1607	71.62		.50	
AB-1608	80.62			
AB-1609	89.62			
AB-1610	98.62			

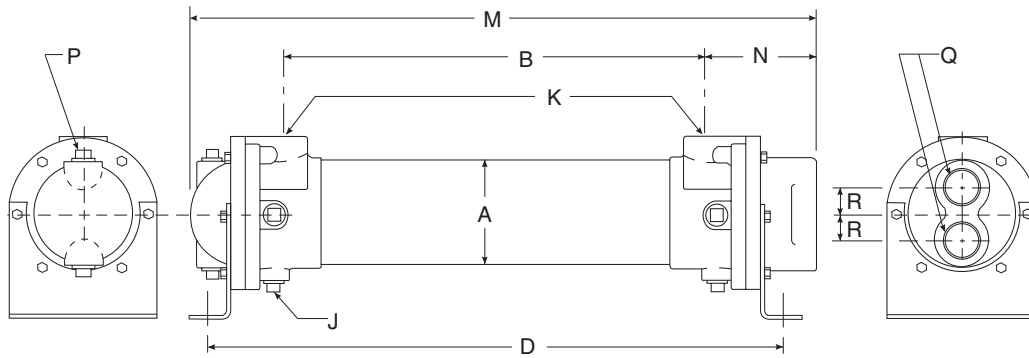

TWO PASS (TP)

Model	M	N	P NPT	Q NPT	R
AB-701	13.28				
AB-702	22.28	3.30	(2)	1.00	.88
AB-703	31.28				
AB-704	40.28				
AB-1002	23.29				
AB-1003	32.29	3.80	(2)	1.50	1.19
AB-1004	41.29		.38		
AB-1202	23.94				
AB-1203	32.81				
AB-1204	41.69				
AB-1205	50.69				
AB-1206	59.81	4.56	(2)	2.00	1.44
AB-1207	68.81		.50		
AB-1208	77.69				
AB-1209	86.69				
AB-1210	95.69				
AB-1602	25.10				
AB-1603	34.10				
AB-1604	43.10				
AB-1605	52.10				
AB-1606	61.10	6.08	(2)	2.50	1.88
AB-1607	70.10		.50		
AB-1608	79.10				
AB-1609	88.10				
AB-1610	97.10				

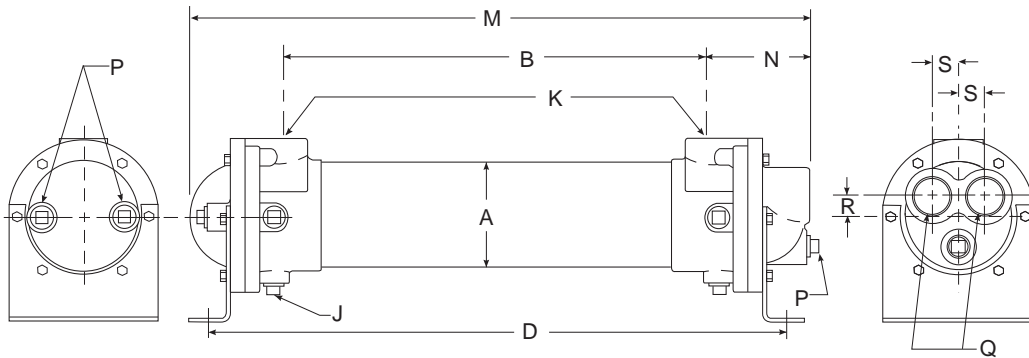

FOUR PASS (FP)

Model	M	N	P NPT	Q NPT	R	S
AB-701	13.42					
AB-702	22.42	3.24	(3)	.75	.62	.88
AB-703	31.42					
AB-704	40.42					
AB-1002	23.55					
AB-1003	32.55	4.06	(3)	1.00	.75	1.19
AB-1004	41.55		.38			
AB-1202	24.44					
AB-1203	33.31					
AB-1204	42.19					
AB-1205	51.19					
AB-1206	60.31	4.90	(3)	1.50	1.06	1.44
AB-1207	69.31		.50			
AB-1208	78.19					
AB-1209	87.19					
AB-1210	96.19					
AB-1602	26.72					
AB-1603	35.72					
AB-1604	44.72					
AB-1605	53.72					
AB-1606	62.72	6.48	(3)	2.00	1.38	1.88
AB-1607	71.72		.50			
AB-1608	80.72					
AB-1609	89.72					
AB-1610	98.72					

COMMON DIMENSIONS & WEIGHTS

Model	A	B	C	D	E	F	G	H	J NPT	K NPT	L	Approx. Weight	Model
AB-401		7.62		10.91								7	AB-401
AB-402		16.62		20.91	1.94	2.62	.88	.41φ	-	.50	1.72	10	AB-402
AB-701		7.00		12.38								23	AB-701
AB-702		16.00		21.38					(2)	1.00	2.69	29	AB-702
AB-703	3.66	25.00	6.25	30.38	3.62	5.25	1.50	.44φ x 1.00	.38	1.00	2.69	33	AB-703
AB-704		34.00		39.38								49	AB-704
AB-1002		15.50		21.62								54	AB-1002
AB-1003		24.50		30.62	4.00	6.75	2.00	.44φ x 1.00	(6)	1.50	3.06	76	AB-1003
AB-1004	5.13	33.50	7.38	39.62					.38	1.50	3.06	82	AB-1004
AB-1202		14.62		21.50								79	AB-1202
AB-1203		23.50		30.38								98	AB-1203
AB-1204		32.38		39.25								115	AB-1204
AB-1205		41.38		48.25								130	AB-1205
AB-1206		50.50		57.38					(6)	2.00	3.44	150	AB-1206
AB-1207	6.13	59.50	8.81	66.38	4.75	7.50	2.50	.44φ x 1.00	.38	2.00	3.44	170	AB-1207
AB-1208		68.38		75.25								190	AB-1208
AB-1209		77.38		84.25								210	AB-1209
AB-1210		86.38		93.25								230	AB-1210
AB-1602		13.60		22.38								145	AB-1602
AB-1603		22.60		31.38								170	AB-1603
AB-1604		31.60		40.38								200	AB-1604
AB-1605		40.60		49.38								225	AB-1605
AB-1606		49.60	12.13	58.38	6.50	10.00	3.50	.44φ x 1.00	(6)	3.00	4.39	250	AB-1606
AB-1607		58.60		67.38					.38	3.00	4.39	275	AB-1607
AB-1608		67.60		76.38								315	AB-1608
AB-1609		76.60		85.38								350	AB-1609
AB-1610		85.60		94.38								390	AB-1610

note: AIHTI reserves the right to make reasonable design changes without notice.

SAE Series dimensions

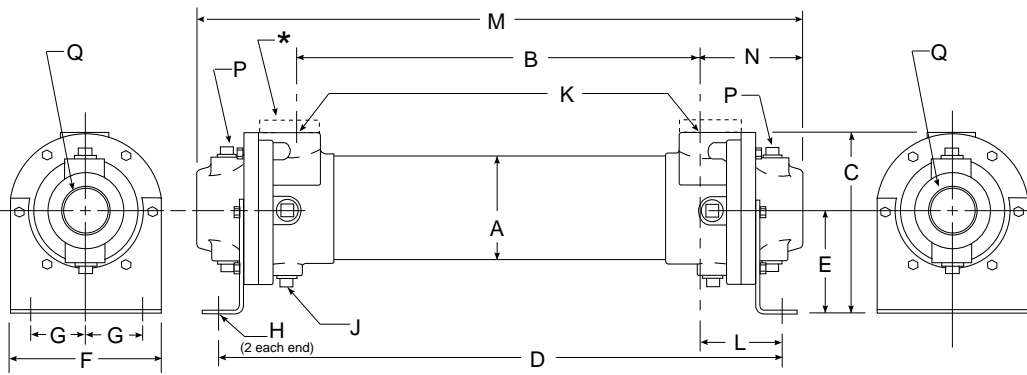

SINGLE PASS (SP)

Model	M	N	P NPT	Q NPT
SAE-401	11.24	1.81	-	1.00
SAE-402	20.24			
SAE-701	13.47			
SAE-702	22.47		(4)	1.50
SAE-703	31.47	3.24	.38	
SAE-704	40.47			
SAE-1002	23.60			
SAE-1003	32.60	4.05	(4)	2.00
SAE-1004	41.60		.38	
SAE-1202	24.38			
SAE-1203	33.25			
SAE-1204	42.12			
SAE-1205	51.12			
SAE-1206	60.25			
SAE-1207	69.25	4.88	(4)	3.00
SAE-1208	78.12		.50	
SAE-1209	87.12			
SAE-1210	96.12			
SAE-1602	26.62			
SAE-1603	35.62			
SAE-1604	44.62			
SAE-1605	53.62			
SAE-1606	62.62	6.52	(4)	4.00
SAE-1607	71.62		.50	
SAE-1608	80.62			
SAE-1609	89.62			
SAE-1610	98.62			

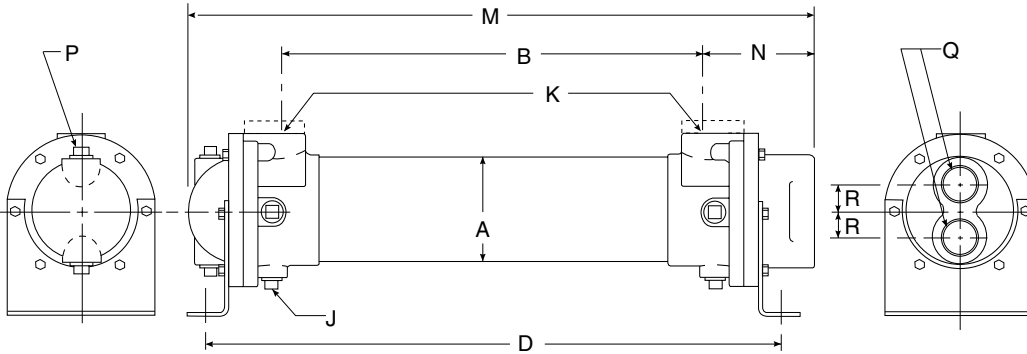

TWO PASS (TP)

Model	M	N	P NPT	Q NPT	R
SAE-701	13.28				
SAE-702	22.28	3.30	(2)	1.00	.88
SAE-703	31.28		.38		
SAE-704	40.28				
SAE-1002	23.29				
SAE-1003	32.29	3.80	(2)	1.50	1.19
SAE-1004	41.29		.38		
SAE-1202	23.94				
SAE-1203	32.81				
SAE-1204	41.69				
SAE-1205	50.69				
SAE-1206	59.81	4.56	(2)	2.00	1.44
SAE-1207	68.81		.50		
SAE-1208	77.69				
SAE-1209	86.69				
SAE-1210	95.69				
SAE-1602	25.10				
SAE-1603	34.10				
SAE-1604	43.10				
SAE-1605	52.10				
SAE-1606	61.10	6.08	(2)	2.50	1.88
SAE-1607	70.10		.50		
SAE-1608	79.10				
SAE-1609	88.10				
SAE-1610	97.10				

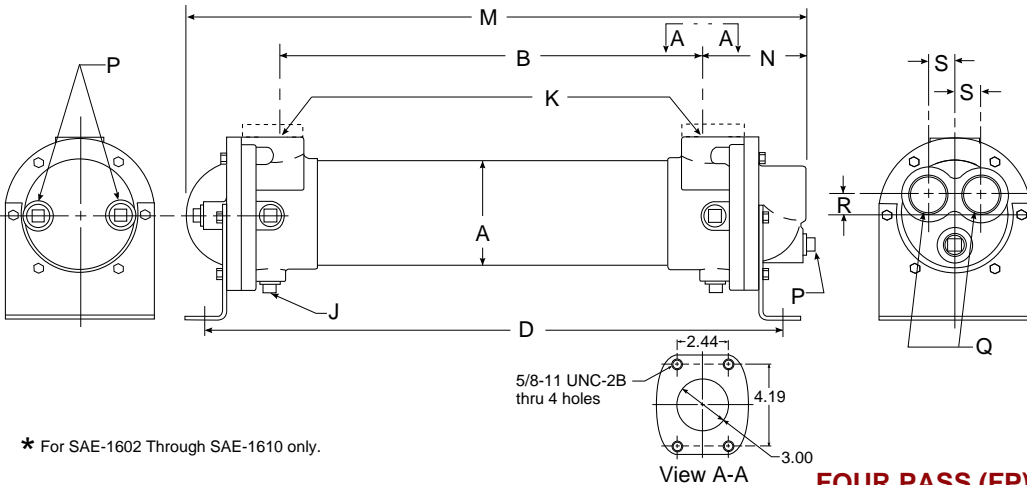

FOUR PASS (FP)

Model	M	N	P NPT	Q NPT	R	S
SAE-701	13.42					
SAE-702	22.42	3.24	(3)	.75	.62	.88
SAE-703	31.42		.38			
SAE-704	40.42					
SAE-1002	23.55					
SAE-1003	32.55	4.06	(3)	1.00	.75	1.19
SAE-1004	41.55		.38			
SAE-1202	24.44					
SAE-1203	33.31					
SAE-1204	42.19					
SAE-1205	51.19					
SAE-1206	60.31	4.90	(3)	1.50	1.06	1.44
SAE-1207	69.31		.50			
SAE-1208	78.19					
SAE-1209	87.19					
SAE-1210	96.19					
SAE-1602	26.72					
SAE-1603	35.72					
SAE-1604	44.72					
SAE-1605	53.72					
SAE-1606	62.72	6.48	(3)	2.00	1.38	1.88
SAE-1607	71.72		.50			
SAE-1608	80.72					
SAE-1609	89.72					
SAE-1610	98.72					

* For SAE-1602 Through SAE-1610 only.

COMMON DIMENSIONS & WEIGHTS

Model	A	B	C	D	E	F	G	H	J NPT	K SAE	L	Approx. Weight	Model
SAE-401	2.13	7.62	3.50	10.91	1.94	2.62	.88	.41φ	-	#8	1.72	7	SAE-401
SAE-402		16.62		20.91						3/4-16		10	SAE-402
SAE-701		7.00		12.38						#16		23	SAE-701
SAE-702	3.66	16.00	6.25	21.38	3.62	5.25	1.50	.44φ x 1.00	(2)	1 5/16-12	2.69	29	SAE-702
SAE-703		25.00		30.38					.38			33	SAE-703
SAE-704		34.00		39.38								49	SAE-704
SAE-1002		15.50		21.62						#24		54	SAE-1002
SAE-1003	5.13	24.50	7.38	30.62	4.00	6.75	2.00	.44φ x 1.00	(6)	1 7/8-12	3.06	76	SAE-1003
SAE-1004		33.50		39.62					.38			82	SAE-1004
SAE-1202		14.62		21.50								79	SAE-1202
SAE-1203		23.50		30.38								98	SAE-1203
SAE-1204		32.38		39.25								115	SAE-1204
SAE-1205		41.38		48.25								130	SAE-1205
SAE-1206		50.50		57.38								150	SAE-1206
SAE-1207	6.13	59.50	8.81	66.38	4.75	7.50	2.50	.44φ x 1.00	(6)	#32	3.44	170	SAE-1207
SAE-1208		68.38		75.25					.38	2 1/2-12		190	SAE-1208
SAE-1209		77.38		84.25								210	SAE-1209
SAE-1210		86.38		93.25								230	SAE-1210
SAE-1602		13.60		22.38								145	SAE-1602
SAE-1603		22.60		31.38								170	SAE-1603
SAE-1604		31.60		40.38								200	SAE-1604
SAE-1605		40.60		49.38								225	SAE-1605
SAE-1606		49.60	12.13	58.38	6.50	10.00	3.50	.44φ x 1.00	(6)	3.0" Four bolt Flange	4.39	250	SAE-1606
SAE-1607		58.60		67.38					.38			275	SAE-1607
SAE-1608		67.60		76.38								315	SAE-1608
SAE-1609		76.60		85.38								350	SAE-1609
SAE-1610		85.60		94.38								390	SAE-1610

note: AIHTI reserves the right to make reasonable design changes without notice.

STS Series dimensions

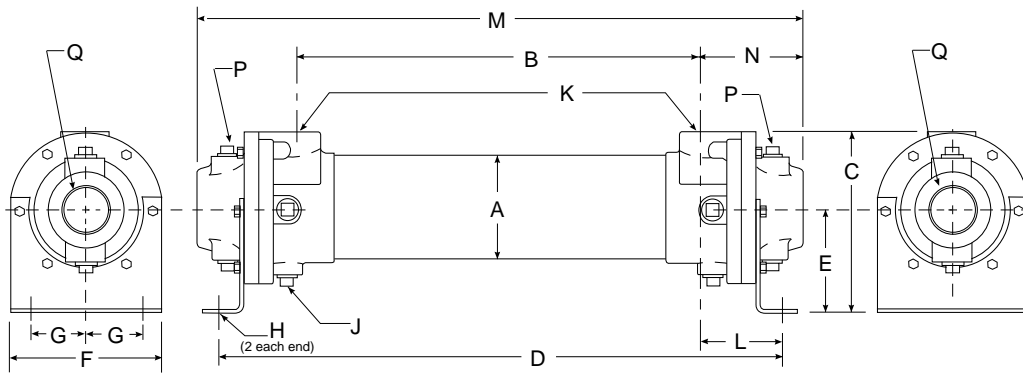

SINGLE PASS (SP)

Model	M	N	P NPT	Q NPT
STS-401	11.24	1.81	-	1.00
STS-402	20.24			
STS-701	13.47			
STS-702	22.47		(4)	
STS-703	31.47	3.24	.38	1.50
STS-704	40.47			
STS-1002	23.60			
STS-1003	32.60	4.05	(4)	2.00
STS-1004	41.60		.38	
STS-1202	24.38			
STS-1203	33.25			
STS-1204	42.12			
STS-1205	51.12			
STS-1206	60.25			
STS-1207	69.25	4.88	(4)	3.00
STS-1208	78.12		.50	
STS-1209	87.12			
STS-1210	96.12			
STS-1602	26.62			
STS-1603	35.62			
STS-1604	44.62			
STS-1605	53.62			
STS-1606	62.62	6.52	(4)	4.00
STS-1607	71.62		.50	
STS-1608	80.62			
STS-1609	89.62			
STS-1610	98.62			

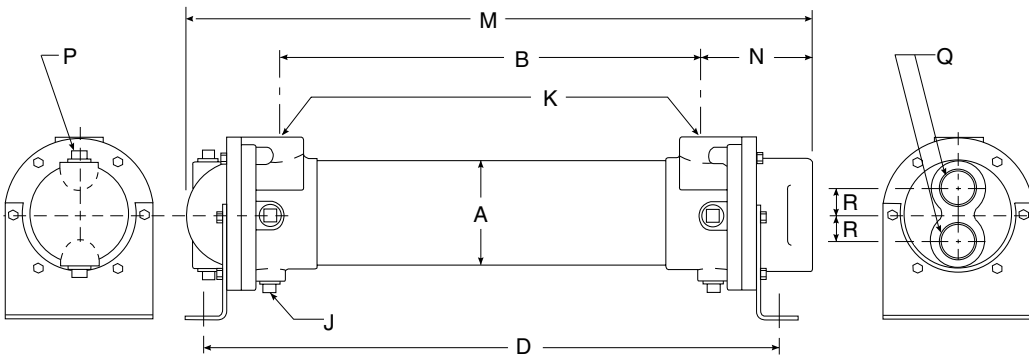

TWO PASS (TP)

Model	M	N	P NPT	Q NPT	R
STS-701	13.28				
STS-702	22.28	3.30	(2)	1.00	.88
STS-703	31.28		.38		
STS-704	40.28				
STS-1002	23.29				
STS-1003	32.29	3.80	(2)	1.50	1.19
STS-1004	41.29		.38		
STS-1202	23.94				
STS-1203	32.81				
STS-1204	41.69				
STS-1205	50.69				
STS-1206	59.81	4.56	(2)	2.00	1.44
STS-1207	68.81		.50		
STS-1208	77.69				
STS-1209	86.69				
STS-1210	95.69				
STS-1602	25.10				
STS-1603	34.10				
STS-1604	43.10				
STS-1605	52.10				
STS-1606	61.10	6.08	(2)	2.50	1.88
STS-1607	70.10		.50		
STS-1608	79.10				
STS-1609	88.10				
STS-1610	97.10				

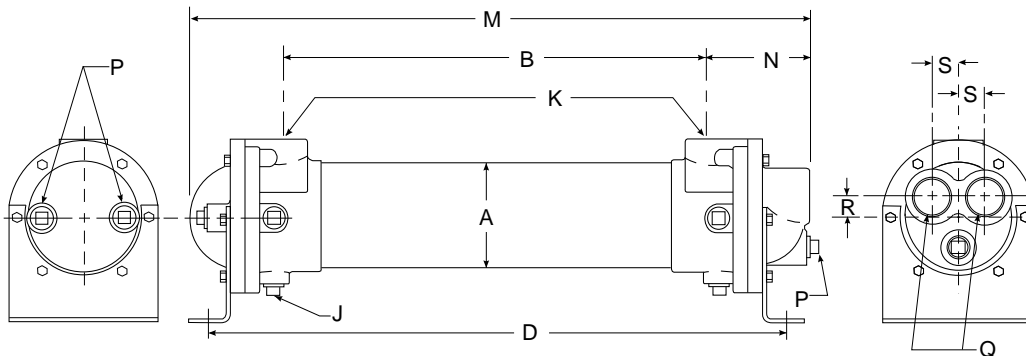

FOUR PASS (FP)

Model	M	N	P NPT	Q NPT	R	S
STS-701	13.42					
STS-702	22.42	3.24	(3)	.75	.62	.88
STS-703	31.42		.38			
STS-704	40.42					
STS-1002	23.55					
STS-1003	32.55	4.06	(3)	1.00	.75	1.19
STS-1004	41.55		.38			
STS-1202	24.44					
STS-1203	33.31					
STS-1204	42.19					
STS-1205	51.19					
STS-1206	60.31	4.90	(3)	1.50	1.06	1.44
STS-1207	69.31		.50			
STS-1208	78.19					
STS-1209	87.19					
STS-1210	96.19					
STS-1602	26.72					
STS-1603	35.72					
STS-1604	44.72					
STS-1605	53.72					
STS-1606	62.72	6.48	(3)	2.00	1.38	1.88
STS-1607	71.72		.50			
STS-1608	80.72					
STS-1609	89.72					
STS-1610	98.72					

COMMON DIMENSIONS & WEIGHTS

Model	A	B	C	D	E	F	G	H	J NPT	K NPT	L	Approx. Weight	Model
STS-401	2.13	7.62	3.50	10.91	1.94	2.62	.88	.41φ	-	.50	1.72	7	STS-401
STS-402		16.62		20.91								10	STS-402
STS-701		7.00		12.38								23	STS-701
STS-702		16.00		21.38					(2)	1.00	2.69	29	STS-702
STS-703	3.66	25.00	6.25	30.38	3.62	5.25	1.50	.44φ x 1.00	.38			33	STS-703
STS-704		34.00		39.38								49	STS-704
STS-1002		15.50		21.62								54	STS-1002
STS-1003		24.50		30.62					(6)	1.50	3.06	76	STS-1003
STS-1004	5.13	33.50	7.38	39.62	4.00	6.75	2.00	.44φ x 1.00	.38			82	STS-1004
STS-1202		14.62		21.50								79	STS-1202
STS-1203		23.50		30.38								98	STS-1203
STS-1204		32.38		39.25								115	STS-1204
STS-1205		41.38		48.25								130	STS-1205
STS-1206		50.50		57.38								150	STS-1206
STS-1207	6.13	59.50	8.81	66.38	4.75	7.50	2.50	.44φ x 1.00	(6)	2.00	3.44	170	STS-1207
STS-1208		68.38		75.25					.38			190	STS-1208
STS-1209		77.38		84.25								210	STS-1209
STS-1210		86.38		93.25								230	STS-1210
STS-1602		13.60		22.38								145	STS-1602
STS-1603		22.60		31.38								170	STS-1603
STS-1604		31.60		40.38								200	STS-1604
STS-1605		40.60		49.38								225	STS-1605
STS-1606		49.60	12.13	58.38	6.50	10.00	3.50	.44φ x 1.00	(6)	3.00	4.39	250	STS-1606
STS-1607		58.60		67.38					.38			275	STS-1607
STS-1608		67.60		76.38								315	STS-1608
STS-1609		76.60		85.38								350	STS-1609
STS-1610		85.60		94.38								390	STS-1610

note: AIHTI reserves the right to make reasonable design changes without notice.

EAB Series dimensions

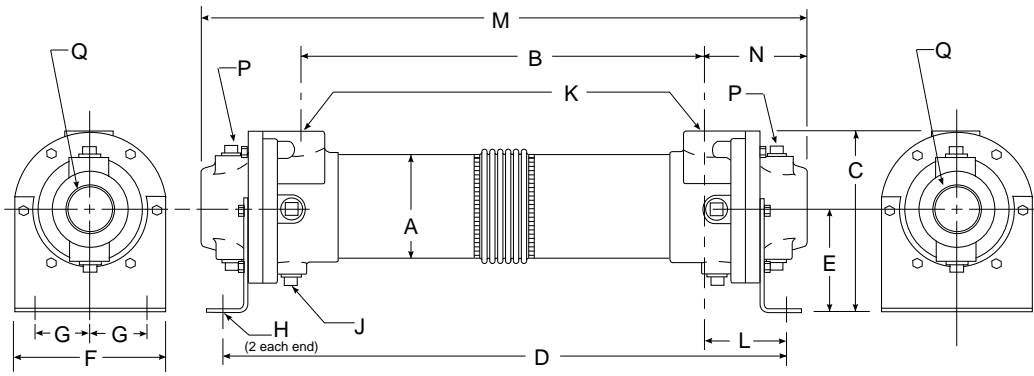

SINGLE PASS (SP)

Model	M	N	P NPT	Q NPT
EAB-701	13.47	3.24	(4) .38	1.50
EAB-702	22.47			
EAB-703	31.47			
EAB-704	40.47			
EAB-1002	23.60	4.05	(4) .38	2.00
EAB-1003	32.60			
EAB-1004	41.60			
EAB-1202	24.38			
EAB-1203	33.25	4.88	(4) .50	3.00
EAB-1204	42.12			
EAB-1205	51.12			
EAB-1206	60.25			
EAB-1207	69.25			
EAB-1208	78.12			
EAB-1209	87.12			
EAB-1210	96.12			
EAB-1602	26.62	6.52	(4) .50	4.00
EAB-1603	35.62			
EAB-1604	44.62			
EAB-1605	53.62			
EAB-1606	62.62			
EAB-1607	71.62			
EAB-1608	80.62			
EAB-1609	89.62			
EAB-1610	98.62			

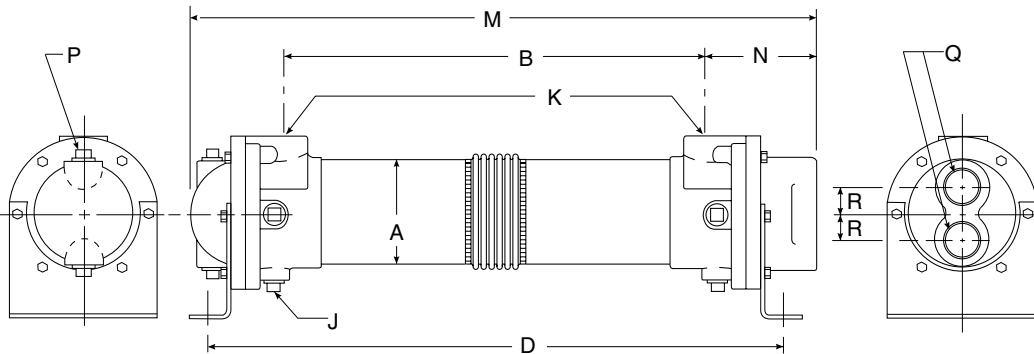

TWO PASS (TP)

Model	M	N	P NPT	Q NPT	R
EAB-701	13.28	3.30	(2) .38	1.00	.88
EAB-702	22.28				
EAB-703	31.28				
EAB-704	40.28				
EAB-1002	23.29	3.80	(2) .38	1.50	1.19
EAB-1003	32.29				
EAB-1004	41.29				
EAB-1202	23.94				
EAB-1203	32.81	4.56	(2) .50	2.00	1.44
EAB-1204	41.69				
EAB-1205	50.69				
EAB-1206	59.81				
EAB-1207	68.81				
EAB-1208	77.69				
EAB-1209	86.69				
EAB-1210	95.69				
EAB-1602	25.10	6.08	(2) .50	2.50	1.88
EAB-1603	34.10				
EAB-1604	43.10				
EAB-1605	52.10				
EAB-1606	61.10				
EAB-1607	70.10				
EAB-1608	79.10				
EAB-1609	88.10				
EAB-1610	97.10				

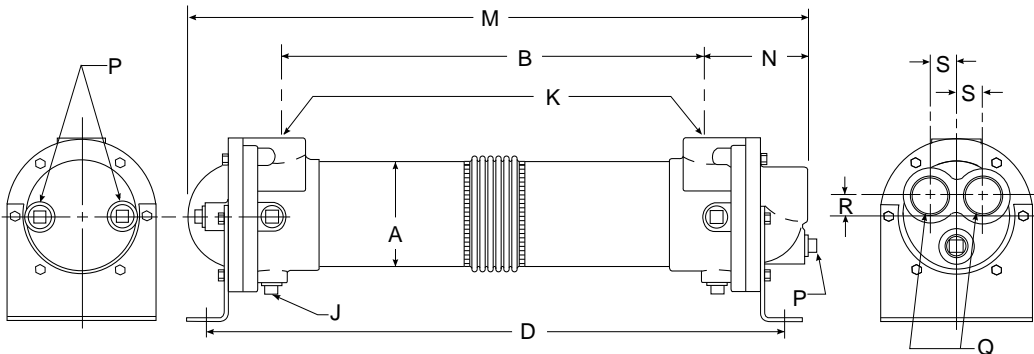

FOUR PASS (FP)

Model	M	N	P NPT	Q NPT	R	S
EAB-701	13.42	3.24	(3) .38	.75	.62	.88
EAB-702	22.42					
EAB-703	31.42					
EAB-704	40.42					
EAB-1002	23.55	4.06	(3) .38	1.00	.75	1.19
EAB-1003	32.55					
EAB-1004	41.55					
EAB-1202	24.44					
EAB-1203	33.31	4.90	(3) .50	1.50	1.06	1.44
EAB-1204	42.19					
EAB-1205	51.19					
EAB-1206	60.31					
EAB-1207	69.31					
EAB-1208	78.19					
EAB-1209	87.19					
EAB-1210	96.19					
EAB-1602	26.72	6.48	(3) .50	2.00	1.38	1.88
EAB-1603	35.72					
EAB-1604	44.72					
EAB-1605	53.72					
EAB-1606	62.72					
EAB-1607	71.72					
EAB-1608	80.72					
EAB-1609	89.72					
EAB-1610	98.72					

COMMON DIMENSIONS & WEIGHTS

Model	A	B	C	D	E	F	G	H	J NPT	K NPT	L	Approx. Weight	Model
EAB-701	3.66	7.00	6.25	12.38	3.62	5.25	1.50	.44φ x 1.00	(2) .38	1.00	2.69	23	EAB-701
EAB-702		16.00		21.38								29	EAB-702
EAB-703		25.00		30.38								33	EAB-703
EAB-704		34.00		39.38								49	EAB-704
EAB-1002	5.13	15.50	7.38	21.62	4.00	6.75	2.00	.44φ x 1.00	(6) .38	1.50	3.06	54	EAB-1002
EAB-1003		24.50		30.62								76	EAB-1003
EAB-1004		33.50		39.62								82	EAB-1004
EAB-1202		14.62		21.50								8.81	25.50
EAB-1203	23.50	30.38	98	EAB-1203									
EAB-1204	32.38	39.25	115	EAB-1204									
EAB-1205	41.38	48.25	130	EAB-1205									
EAB-1206	50.50	57.38	150	EAB-1206									
EAB-1207	59.50	66.38	170	EAB-1207									
EAB-1208	68.38	75.25	190	EAB-1208									
EAB-1209	77.38	84.25	210	EAB-1209									
EAB-1210	86.38	93.25	230	EAB-1210									
EAB-1602	8.00	13.60	12.13	22.38	6.50	10.00	3.50	.44φ x 1.00	(6) .38	3.00	4.39	145	EAB-1602
EAB-1603		22.60		31.38								170	EAB-1603
EAB-1604		31.60		40.38								200	EAB-1604
EAB-1605		40.60		49.38								225	EAB-1605
EAB-1606		49.60		58.38								250	EAB-1606
EAB-1607		58.60		67.38								275	EAB-1607
EAB-1608		67.60		76.38								315	EAB-1608
EAB-1609		76.60		85.38								350	EAB-1609
EAB-1610		85.60		94.38								390	EAB-1610

note: AIHTI reserves the right to make reasonable design changes without notice.

AB, SAE, STS, & EAB Series *installation & maintenance*

PIPING HOOK-UP

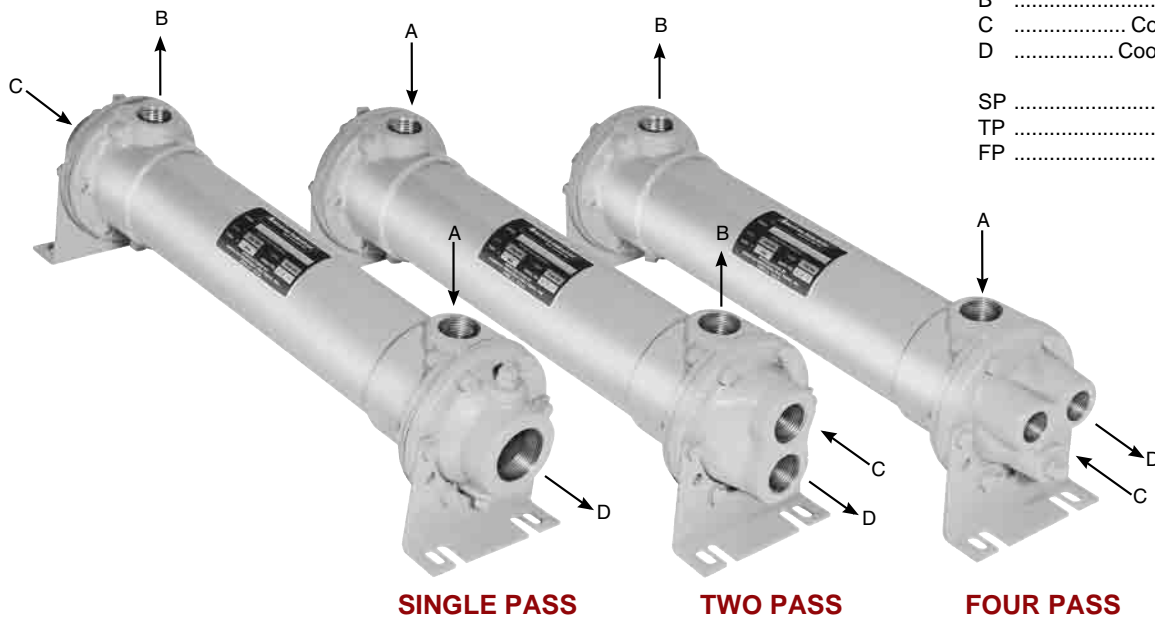

A Hot fluid to be cooled
 B Cooled fluid
 C Cooling water in
 D Cooling water out

SP Single Pass
 TP Two Pass
 FP Four Pass

SINGLE PASS

TWO PASS

FOUR PASS

Receiving / Installation

a) Inspect unit for any shipping damage before uncrating. Indicate all damages to the trucking firms' delivery person, and mark it on the receiving bill before accepting the freight. Make sure that there is no visible damage to the outside surface of the heat exchanger. The published weight information located in this brochure is approximate. True shipment weights are determined at the time of shipping and may vary. Approximate weight information published herein is for engineering approximation purposes and should not be used for exact shipping weight. Since the warranty is based upon the unit date code located on the model identification tags, removal or manipulation of the identification tags will void the manufacturers warranty.

b) When handling the shell & tube heat exchanger, special care should be taken to avoid dropping the unit since mishandling could cause the heat exchanger to crack and leak externally. Mishandling of the unit is not covered under the manufacturers warranty. All units are shipped with partial wood/corrugated cardboard containers for safe handling.

c) Storage: American Industrial heat exchangers are protected against the elements during shipment. If the heat exchanger cannot be installed and put into operation immediately upon receipt, certain precautions are required to prevent deterioration during storage. The responsibility for integrity of the heat exchanger(s) is assumed by the user. American Industrial will not be responsible for damage, corrosion, or other deterioration of the heat exchanger during transit or storage.

Proper storage practices are important when considering the high costs of repair or replacement, and the possible delays for items which require long lead times for manufacture. The following listed practices are provided solely as a convenience to the user, who shall make their own decision on whether to use all or any of them.

- 1) Heat exchangers not to be placed in immediate service, require precautionary measures to prevent corrosion or contamination.
- 2) Heat exchangers made of ferrous materials, may be pressure-tested using compressed air at the factory. Residual oil coating on the inside surfaces of the heat exchanger(s) as a result of flushing does not discount the possibility of internal corrosion. Upon receipt, fill the heat exchanger(s) with the appropriate grade of oil or apply a corrosion preventing inhibitor for storage.
- 3) Corrosion protection compounds for interior surfaces for long term storage or other applications are applied solely at the request of customers. Upon request, American Industrial can provide a customer approved corrosion preventative if available when included in the original purchase order specifications.
- 4) Remove all dirt, water, ice, or snow and wipe dry before moving heat exchanger(s) into storage. Heat exchangers are generally shipped

empty, open drain plugs to remove any accumulated condensation moisture, then reseal. Accumulation of moisture usually indicates corrosion has already started and remedial action should be taken.

- 5) Store in a covered, environmentally stable area. The ideal storage environment for heat exchangers is in a dry, low-humidity atmosphere which is sealed to prevent the entry of blowing dust, rain, or snow. Maintain in atmospheric temperatures between 70°F and 105°F (Large temperature swings may cause condensation and moisture to form on steel components, threads, shell, etc...) Use thermometers and humidity indicators and maintain the atmosphere at 40% relative humidity, or lower.

d) Standard Enamel Coating: American Industrial provides its standard products with a normal base coat of oil base air cure enamel paint. The enamel paint is applied as a temporary protective and esthetic coating prior to shipment. While the standard enamel coating is durable, American Industrial does not warranty it as a long-term finish coating. It is strongly suggested that a more durable final coating be applied after installation or prior to long-term storage in a corrosive environment to cover any accidental scratches, enhance esthetics, and further prevent corrosion. It is the responsibility of the customer to provide regular maintenance against chips, scratches, etc... and regular touch up maintenance must be provided for long-term benefits and corrosion prevention.

e) Special Coatings: American Industrial offers as customer options, Air-Dry Epoxy, and Heresite (Air-Dry Phenolic) coatings at additional cost. American Industrial offers special coatings upon request, however American Industrial does not warranty coatings to be a permanent solution for any equipment against corrosion. It is the responsibility of the customer to provide regular maintenance against chips, scratches, etc... and regular touch up maintenance must be provided for long-term benefits and corrosion prevention.

f) American Industrial recommends that the equipment supplied should be installed by qualified personnel who have solid understanding of system design, pressure and temperature ratings, and piping assembly. Verify the service conditions of the system prior to applying any shell & tube heat exchanger. If the system pressure or temperature does not fall within the parameters on model rating tag located on the heat exchanger, contact our factory prior to installation or operation.

g) Plan the installation to meet the requirements indicated on the piping installation diagram as illustrated above. It is recommended to put the hot fluid to be cooled through the shell side and the cold fluid through the tube side. The indicated port assembly sequence in the diagram maximizes the performance, and minimizes the possibility of thermal shock.

AB, SAE, STS, & EAB Series *installation & maintenance*

In instances where the fluids are required to be reversed, *hot fluid in the tubes and cold fluid in the shell* the heat exchanger will work with reduced performance. Installation may be vertical or horizontal or a combination thereof. However, the installation must allow for complete draining of the heat exchanger regardless of single pass, two pass, or four pass construction. Complete drainage is important to prevent the heat exchanger from freezing, over-heating of a fluid, or mineral deposit buildup.

For fixed bundle heat exchangers, provide sufficient clearance at one end to allow for the removal or replacement of tubes. On the opposite end, provide enough space to allow removal of the complete bonnet to provide sufficient clearance to permit tube rolling and cleaning. Allow accessible room for scheduled cleaning as needed. Include thermometer wells and pressure gauge pipe ports in piping to and from the heat exchanger located as close to the heat exchanger as possible. For more information please contact American Industrial.

h) When installing a series EAB heat exchanger (expansion bellow), it is recommended to use a shoulder bolt to allow the heat exchanger to move freely while expanding and contracting due to high differential temperatures.

i) It is recommended to use flexible hose wherever possible to reduce vibration and allow slight movement. However, hoses are not required. Hydraulic carrying lines should be sized to handle the appropriate flow and to meet system pressure drop requirements based upon the systems parameters, and not based upon the units supply and return connection size. We recommend that a low cracking pressure direct acting relief valve be installed at the heat exchanger inlet to protect it from pressure spikes by bypassing oil in the event the system experiences a high flow surge. If preventative filtration is used it should be located ahead of the cooler on both shell and tube side to catch any scale or sludge from the system before it enters the cooler. Failure to install filters ahead of the heat exchanger could lead to possible heat exchanger failure due to high pressure if the system filters plug.

j) Standard shell & tube coolers are built with a rolled tube-sheet construction. However, the differential operating temperature between the entering shell side fluid and the entering tube side fluid should not exceed 150°F. If this condition exists, a severe thermal shock could occur leading to product failure and mixing of the fluids. For applications with a differential temperatures of 150°F or more, we recommend using a series with a floating tube-sheet, u-tube, or expansion joint to reduce the potential for the effects of thermal shock.

k) Water requirements vary from location to location. If the source of cooling water is from other than a municipal water supply, it is recommended that a water strainer be installed ahead of the heat exchanger to prevent dirt and debris from entering and clogging the flow passages. If a water modulating valve is used it is recommended to be installed at the inlet to the cooler to regulate the water flow.

l) For steam service, or other related applications, please consult our engineering department for additional information.

Maintenance

a) Inspect the heat exchanger for loosened bolts, connections, rust spots, corrosion, and for internal or external fluid leakage. Any corroded surfaces should be cleaned and recoated with paint.

b) **Shell side:** In many cases with clean hydraulic system oils it will not be necessary to flush the interior of the shell side of the cooler. In circumstances where the quality of hydraulic fluid is in question, the shell side should be disconnected and flushed on a yearly basis with a clean flushing oil/solvent to remove any sludge that has been deposited. For severe cases where the unit is plugged and cannot be flushed clean with solvent, the heat exchanger should be replaced to maintain the proper cooling performance.

c) **Tube side:** In many cases it will be necessary to clean the tube side of the heat exchanger due to poor fluid quality, debris, calcium deposits, corrosion, mud, sludge, seaweed, etc.... To clean the tube side, flush with clean water or any good quality commercial cleaner that does not attack the particular material of construction. With straight tube heat exchangers you can use a rod to carefully push any debris out of the tubes.

d) **Zinc anodes** are normally used to reduce the risk of failure due to electrolysis. Zinc anodes are a sacrificial component designed to wear and dissolve through normal use. Normally, zinc anodes are applied to the water supply side of the heat exchanger. Depending upon the amount of corrosive action, one, two, three, or more anodes can be applied to help further reduce the risk of failure. American Industrial Heat Transfer, Inc. offers zinc anodes as an option, to be specified and installed at the request of our customers. It is the responsibility of the customer to periodically check and verify the condition of the zinc anode and replace it as needed.

Applications vary due to water chemical makeup and quality, material differences, temperature, flow rate, piping arrangements, and machine grounding. For those reasons, zinc anodes do not follow any scheduled factory predetermined maintenance plan moreover they must be checked routinely by the customer, and a maintenance plan developed based upon the actual wear rate.

If substantial wear occurs or zinc dissolves without replacement, premature failure or permanent damage may occur to the heat exchanger. American Industrial does not warranty customer applications. It is the responsibility of the customer to verify and apply the proper system materials of construction and overall system requirements. Failures resulting from properly applied or misapplied use of zinc anode(s) into non-specified or specified applications will be the sole responsibility of the customer.

e) A routine maintenance schedule should be developed and adjusted to meet your systems requirements based upon water quality, etc.... Failure to regularly maintain and clean your heat exchanger can result in a reduction in operational performance and life expectancy.

Note: Since applications can vary substantially, the installation and maintenance information contained in this catalog should be used as a basic guideline. The safe installation, maintenance, and use of any American Industrial Heat Transfer, Inc. heat exchanger are solely the responsibility of the user.

